

NAU 2018 Collegiate Wind Competition

Midpoint Report

Test Team A

Kory Joe

Devon Hardy

Aaron DeLuca

Evan Heiland

Qian Zhao

Soud Alsahli

2017-2018



Project Sponsor: The U.S. Department of Energy (DOE) & The National Renewable Energy Laboratory (NREL)

Faculty Advisors: David Willy, Dr. Karin Wadsack, Dr. Venkata Yaramasu, and Dr. Tom Acker

Instructor: Dr. Sarah Oman

DISCLAIMER

This report was prepared by students as part of a university course requirement. While considerable effort has been put into the project, it is not the work of licensed engineers and has not undergone the extensive verification that is common in the profession. The information, data, conclusions, and content of this report should not be relied on or utilized without thorough, independent testing and verification. University faculty members may have been associated with this project as advisors, sponsors, or course instructors, but as such they are not responsible for the accuracy of results or conclusions.

TABLE OF CONTENTS

DISCLAIMER	i
TABLE OF FIGURES	iiv
TABLE OF TABLES	
iv	
1 BACKGROUND	1
1.1 Introduction.....	1
1.2 Project Description.....	1
1.3 Original System.....	2
1.3.1 Original System Structure.....	2
1.3.2 Original System Operation.....	2
1.3.3 Original System Performance.....	2
1.3.4 Original System Deficiencies.....	3
2 REQUIREMENTS	4
2.1 Customer Requirements.....	4
2.2 Engineering Requirements (ERs).....	4
2.3 Testing Procedure.....	5
2.3.1 Blades.....	5
2.3.2 Drivetrain.....	5
2.3.3 Bearings.....	6
2.3.4 Generator.....	6
2.3.5 DC-DC Converter.....	6
2.3.6 PCB.....	6
2.4 House of Quality (HoQ).....	6
3 EXISTING DESIGNS	8
3.1 Design Research.....	8
3.1.1 Blades.....	8
3.1.2 Drivetrain.....	8
3.1.3 Bearings.....	8
3.1.4 Generator.....	9
3.1.5 DC-DC Converter.....	9
3.1.6 PCB.....	9
3.2 System Level.....	10
3.2.1 Subsystem Level: Blades.....	10
3.2.2 Subsystem Level: Drivetrain.....	11
3.2.3 Subsystem Level: Bearings.....	11
3.2.4 Subsystem Level: Generator.....	11
3.2.5 Subsystem Level: DC-DC Converter.....	12
3.2.6 Subsystem Level: Printed Circuit Board (PCB).....	12
3.3 Functional Decomposition.....	13
3.3.1 Black Box Model.....	13
3.3.2 Functional Flow Model/Gantt Chart.....	14
4 DESIGNS CONSIDERED	15
4.1 Blades.....	15
4.2 Drivetrain.....	17
4.3 Bearings.....	18
4.4 Generator.....	19
4.5 DC-DC Converter.....	21
4.6 PCB.....	22
5 DESIGN SELECTED	25

5.1	<i>Rationale for Design Selection</i>	25
5.1.1	<i>Blades</i>	25
5.1.2	<i>Drivetrain</i>	25
5.1.3	<i>Bearings</i>	25
5.1.4	<i>Generator</i>	26
5.1.5	<i>DC-DC Converter</i>	26
5.1.6	<i>PCB</i>	27
5.2	<i>Design Description</i>	27
5.2.1	<i>Blades</i>	27
5.2.2	<i>Drivetrain</i>	31
5.2.3	<i>Description: Bearings</i>	31
5.2.4	<i>Generator</i>	32
5.2.5	<i>DC-DC Converter</i>	33
5.2.6	<i>PCB</i>	34
6	PROPOSED DESIGN	36
6.1	<i>3 ULTEM 9085 Blades</i>	36
6.2	<i>Direct Drive Aluminum 7075 Shaft</i>	37
6.3	<i>Timken Co. 619/8-2RS Single-Row Deep-Groove Ball Bearings</i>	37
6.4	<i>Permanent Magnet Synchronous AC Generator</i>	37
6.5	<i>3-Channel Interleaved Boost Converter</i>	37
6.6	<i>PCB Inductors and MOSFETs</i>	38
6.8.1	<i>Blades</i>	39
6.8.2	<i>Drivetrain</i>	39
6.8.3	<i>Bearings</i>	40
6.8.4	<i>Generator</i>	40
6.8.5	<i>DC-DC Converter and PCB</i>	40
7	IMPLEMENTATION	41
7.1	<i>Manufacturing</i>	41
7.1.1	<i>Blades</i>	41
7.1.2	<i>Drivetrain</i>	41
7.1.3	<i>Bearing</i>	41
7.1.4	<i>PCB</i>	41
7.1.5	<i>Coding</i>	42
7.2	<i>Design Changes</i>	42
7.2.1	<i>Blades</i>	42
7.2.2	<i>Drivetrain</i>	42
7.2.3	<i>Bearing</i>	42
7.2.4	<i>Generator</i>	43
7.2.5	<i>DC-DC Converter</i>	43
7.2.6	<i>PCB</i>	44
8	REFERENCES	45
	APPENDIX A: House of Quality (HoQ)	47
	APPENDIX B: Functional Decomposition	48
	APPENDIX C: Gantt Chart	49
	APPENDIX E: Shaft Fatigue Analysis MatLab Code	50
	APPENDIX D: Bill of Materials	52

TABLE OF FIGURES

Figure 1: Wind Turbine Black Box Model	14
Figure 2: Functional Flow Model	14
Figure 3: Fluid Nozzles to Increase Reynolds Number	15
Figure 4: Telescoping Blade	16
Figure 5: Curved Blade	16
Figure 6: Blade with Shroud	17
Figure 7: Conventional Blade	17
Figure 8: Gearbox Drivetrain [13]	18
Figure 9: Direct Drive Shaft [14]	18
Figure 10: Single-Row Deep-Groove Ball Bearing [15]	19
Figure 11: Tapered Roller Bearing [16]	19
Figure 12: Simulink Generator Model	20
Figure 13: DC Generator [17]	20
Figure 14: Boost Converter	21
Figure 15: Interleaved Boost Converter	22
Figure 16: Single-Side Board	23
Figure 17: Double-Side Board	23
Figure 18: Multi-Layer Board	23
Figure 19: BreadBoard	24
Figure 20: Current Blade Design	29
Figure 21: Current Rotor Design	29
Figure 22: Power vs Wind Speed Graph	30
Figure 23: Current Blade in Solidworks	30
Figure 24: CAD model of the Direct Drive Shaft	31
Figure 25: Timken Co. 619/8-2RS Single-Row Deep-Groove Ball Bearing Drawing [20]	32
Figure 26: Sunny Sky X4108S	33
Figure 27: Three-Channel Interleaved Boost Converter	34
Figure 28: Inductor Selection Tool [21]	35
Figure 29: MOSFET Selection Tool [22]	35
Figure 30: CAD Image of Overall Wind Turbine Design	36
Figure 31: Blade in Solidworks	37
Figure 32: New Drivetrain Design	42
Figure 33: Brake Assembly Shaft Pillow Block	43
Figure 34: Final Generator Design Decision	43

TABLE OF TABLES

Table 1:Customer Requirements and Rationale.....	4
Table 2:Engineering Requirements and Rationale.....	4
Table 3: Partial House of Qualities.....	7
Table 4: Drivetrain Decision Matrix.....	25
Table 5: Bearings for drivetrain and Yaw Mechanism Decision Matrix.....	26
Table 6:. Generator Decision Matrix.....	26
Table 7: DC-DC Converter Decision Matrix.....	27
Table 8: PCB Decision Matrix.....	27
Table 9: Outputs from MATLAB. First 3 columns are inputs for Qblade.....	28
Table 10: Possible Generators.....	32
Table 11: Partial BOM.....	39

1 BACKGROUND

1.1 Introduction

The project goal is to build a wind turbine that will compete in the Collegiate Wind Competition (CWC), which is sponsored by the U.S. Department of Energy (DOE) and National Renewable Energy Laboratory (NREL). For the CWC, collegiate teams from around America compete against one another in three competition challenges. The competition categories listed within the CWC 2018 Rules and Requirements include:

1. Create a research supported market business plan and a conceptual-level technical development design for a marketable wind power system.
2. Manufacture a safe and reliably operating mechanical, electrical, and aerodynamic wind turbine and load design for testing in an on-site wind tunnel.
3. For the wind turbine, manufacture an electrical control system that can maintain a constant voltage feeding into a competition-provided variable-resistance load, which is conducted during the durability portion of the turbine testing (utilizing a competition-provided storage element to balance source and load energy) [1].

The Northern Arizona University (NAU) CWC 2018 team is fully responsible for constructing a wind turbine and providing team transportation to and from the competition. The overall NAU team has been split up into three different teams: Market Team, Test Team A, and Test Team B. Together the two test teams will design and construct the working turbine for NAU that fits into a 45cm by 45cm by 45cm cube [1]. This report was based on the components that Test Team A was responsible for designing, which were the:

- Blades
- Drivetrain
- Bearings for the drivetrain
- Generator
- Direct Current to Direct Current (DC-DC) Converter
- Printed Circuit Board (PCB).

Therefore, the goal of the overall project relevant to this report is to design and construct the listed wind turbine components.

This project provides hands on work experience that can be expected within the wind energy industry. Wind power at its current rate is “projected to double by 2020 and again in 2030,” which means that there is a growing number of employment opportunities within the wind energy industry [2]. This project builds relevant experience which is needed to fill the expanding job force within the wind energy industry.

1.2 Project Description

According to the project description on the DOE CWC website [1]:

*The 2018 Collegiate Wind Competition will be held at American Wind Energy Association WINDPOWER in Chicago, Illinois, from May 8–10. Competing teams will design and build a model wind turbine based on market research and siting considerations, develop a business plan to market the products, and **test the turbines against a set of rigorous performance criteria** judged by a panel of wind industry leaders.*

*The Collegiate Wind Competition challenges undergraduate students to design a wind turbine based on market research, develop a business plan to market the product, **build and test the***

turbine against set requirements, and demonstrate knowledge of opportunities related to wind farm siting.

*Teams participating in the 2018 Collegiate Wind Competition will be expected to research and design a turbine for a grid scenario with a high contribution of renewables. **The turbine should be able to operate in islanded mode.***

From this description and for the scope of this report: the focus of this project was to develop safe and efficient wind turbine components. The components were assembled into a fully designed wind turbine for testing based on the CWC requirements.

1.3 Original System

Throughout competition years, the NAU CWC team's wind turbine has had some common system structures and operations. For this report, the 2016 and 2017 NAU CWC teams' wind turbine design was the analyzed original system. Design testing results from their design and our design considerations dictated the use of the older turbines' components and different components for the overall system. Due to the CWC rules and requirements changing each year, the current wind turbine must be manufactured in accordance to the 2018 rules and requirements. Nonetheless, there were some similarities to the components that have been consistent throughout the competition years. Thus, the design of this report is comparable to the 2016-2017 NAU CWC team's design.

1.3.1 Original System Structure

The 2016 and 2017 NAU CWC teams' wind turbine was a horizontal axis wind turbine (HAWT) with the tower blade dimensions set. The blades were made from carbon fiber material. The team decided on a fixed blade, stall regulated turbine with 4 blades (changing it from 3 blades used by teams from prior years). The drivetrain type was designed as a direct drive shaft with a single-pad disc brake for turbine speed regulation. The bearings for the drivetrain weren't analyzed to the extent to be expected in this report. The generator was a permanent magnet synchronous AC generator. The DC-DC converter previously used is a simple boost converter, with the board layout being done on a breadboard. The PCB used last year was a simple bread board.

1.3.2 Original System Operation

The operations of the 2016-2017 NAU CWC team's wind turbine operated on fixed blades to catch the wind's energy and translate it into mechanical energy. A direct drive shaft then transfers the mechanical rotational energy into an Active Current (AC) generator that is rectified into a DC output. Then, a DC-DC boost converter steps up the power output. The PCB that holds the electronic components and acts as a signal pathway was a breadboard. The use of these systems were based off of the ease of operations associated with the systems. Due to CWC requirements changing each year, our design mirrors the operation of past turbines only when allowed and/or needed.

1.3.3 Original System Performance

The performance of the 2016-2017 NAU CWC team's wind turbine was rated at 22 to 23 Watts at an 11 or 12 meters per second wind speed. The blade performance also showed a tip speed ratio of roughly 2 to 2.3 at different wind speeds ranging from 10 to 18 meters per second. The wind speed provided by the CWC will be 20 meters per second, so the performance of the turbine should be maximized between 10 to 18 meters per second, which is an acceptable range [3]. The goal of this project was to step up the wind turbine performance from last year, which translates directly with the overall design of the wind turbine.

1.3.4 Original System Deficiencies

The 2016-2017 NAU CWC competition team had problems that will be focused on for the wind turbine in current design. The tail didn't work as designed; it had to be redesigned at the competition, because there was too much wake. The PCB broke while in a team members bag on the way to the competition due to improper packaging. The brakes failed at the competition; the design wasn't adequate for the expected loads on the system.

2 REQUIREMENTS

The requirements of the design dictate how successful the performance of the design must be. The customer requirements were set by our customers (the DOE and NREL) for a satisfactory design. The engineering requirements were then derived from customer requirements and represent measurable engineering parameters in relation to design successfulness.

2.1 Customer Requirements

To design a satisfactory wind turbine, the design must meet the customer requirements. The customer requirements were based off of the DOE CWC Rules and Requirements [3] and consultation with our capstone advisor (David Willy) and past CWC competition team members. Some of the requirements were determined logically, while others were given directly. The main requirements for our design and a description of the reason why each requirement was necessary is in Table 1. Meeting these customer requirements guarantee sufficient customer satisfaction from the overall wind turbine design.

Table 1: Customer Requirements and Rationale

Customer Requirement	Requirement Selection Rationale
Power Generation	There has to be power generated by the wind turbine.
Electrical Grounding	There can be no open charge, so circuits must be grounded.
Transportability	The turbine has to be able to be shipped to and from the competition site and carried by the team.
Assembly	The assembly of the wind turbine should not be too complex, so that we can leave room for repairs.
User Friendly	The use of the wind turbine should be as easy as possible for all users, so that there is no confusion at the competition.
Safety	The turbine cannot be harmful to anyone during construction and use.
Durability	The turbine must be able to withstand relevant loading types and values without failure during use.
Maintenance	If failure occurs, the turbine should be easily accessible for maintenance.
Aesthetics	The turbine should look presentable for the competition.
Cost	The turbine cost should not exceed our project budget.

2.2 Engineering Requirements (ERs)

The engineering requirements were derived from the customer requirements or come from our customers directly. They represent measurable parameters that our design must meet or exceed. The measurable parameters were relevant to the design of each wind turbine component. All of the engineering requirements stem from the CWC Rules and Requirements. Table 2 displays the engineering requirements along with a description of the reason why each engineering requirement was necessary. Meeting these engineering requirements guarantee satisfactory wind turbine performance.

Table 2: Engineering Requirements and Rationale

Engineering Requirement	Requirement Selection Rationale
Survivability Wind Speed (m/s)	The wind turbine must be able to survive winds speeds up to 22 ± 2 m/s to survive competition testing.
Fit in 45cm by 45cm by 45cm cube	The wind turbine rotor must be able to fit in a cube for wind tunnel testing with a tolerance of -0.5cm.
Fit in 61cm by 122cm Turbine Door	The wind turbine must be able to be put through the wind tunnel testing turbine door with a tolerance of -0.5cm.
Electric Housing (Y/N)	There must be a housing complex for the electric components of the wind turbine equivalent to or better than the NEMA 1 standard set by the CWC.

Wire and Jacket Length from Turbine Base (m)	The length of the wire and jacket from the turbine base must be at least 1m to and from the load and at least 2m to and from the storage element with a tolerance of +0.2m.
Required Direct Current (DC) at PCC (V)	The DC value at the PCC must be at least 5V and at most 48V.
Zero State of Charge at Test Beginning (C) & (V)	The charge at the beginning of any test must be zero, so as to not expose any charge to people.
Keep Under Energy Storage Rating (V)	The rating of the output into the energy storage unit must be under 16V, or we will fail the test.
Push Shut Down on Command (Y/N)	The wind turbine must have a simple way to shut down the turbine when needed.
Blade Numbers (#)	There must be between 2 to 4 blades on the wind turbine.
Rotor Diameter (cm)	The diameter of the turbine rotor must be below 45cm with a tolerance of about -0.5cm.
Power Curve Generation between 5m/s and 11m/s (W)	The generation of power on the power curve between wind speeds from 5m/s to 11m/s must be maximized ($\sim 10 \pm 2W$).
Cut-in Wind Speed (m/s)	The cut-in wind speed of the wind turbine must be at a wind speed between 2 and 5m/s.
Rated Wind Speed (m/s)	The rated wind speed must be at $11 \pm 0.5m/s$.
Rated Power (W)	The rated power of the turbine must be at about $10 \pm 2W$.
Cut-out Wind Speed (m/s)	The cut-out wind speed must be at $20 \pm 0.5m/s$.
Tip Speed Ratio (#)	The tip speed ratio must be between 5 to 12.
Overall Efficiency (%)	The overall efficiency of the wind turbine must at $40 \pm 10\%$.
Aerodynamic Efficiency (%)	The aerodynamic efficiency must be at $45 \pm 5\%$.
Electric Efficiency (%)	The electrical efficiency must be at $90 \pm 5\%$

2.3 Testing Procedure

2.3.1 Blades

The blades will be tested for several things when they are produced before being put into the final assembly. The first couple of blades that will be printed with the final material will be tested for radial tension as well as bending at the root. This allows to verify whether the blades are likely to break in tension or bending which the blades are subjected to the entire time the turbine is spinning. The radial extension test is to see how much force the blades can be subjected to without deforming or fracturing. This test is important because the blades are subjected to high revolutions per minute (RPM), and with high RPM comes high centrifugal forces. The bending moment at the base of the blades is going to be another area where the blades are going to be subjected to a lot of stress. For the testing of the bending moments the blade roots of the blades will be fixed to something and a force will be applied to the blade tip, perpendicular to width of blade. Having the force applied here will let us know where the blade is likely break. From this test, we will be able to see if the forces applied in this direction will be higher or about what is expected from the wind. The force that is being applied in this direction is from the incoming wind hitting the upper surface of the airfoil. Another test that is going to be conducted is to see if the airflow around blades is separating from the blade caused by imperfections in the blade. If the flow is separating because of finish from the printer, there are a couple of options to try and fix the finish so that its a smooth finish. The blades can either be sanded with a 1000 - 1500 grit sandpaper or the blades could be placed in an Acetone Vapor Bath to smooth the surface of the blades. The decision to use one over the other is going to depend on how much of the surface needed to be smoothed.

2.3.2 Drivetrain

Upon procurement and machining of the drivetrain, higher than expected torques will be applied at their relevant locations to make sure that the shaft will survive at high wind speeds and allow for maximum

power transfer/generation. The braking torque will be applied at the brake insert location and the rotor torque will be applied at the rotor end of the drivetrain. The weight of the rotor will also be placed on the drivetrain by attaching the rotor to the drivetrain. The loads will be applied cumulatively and in order of expected magnitude: rotor weight, rotor torque, and then braking torque. After each loading application, the drivetrain will be inspected for any sign of fatigue or deformation (i.e. crack propagations, elongation, etc.). If there are any signs of failure mode, then either different material will be selected, and/or the drivetrain geometry will be reconsidered and then the test will be repeated.

2.3.3 Bearings

The bearings that will hold the drivetrain in place and allow for rotation has to fit the drivetrain dimension; therefore, the first test will be to connect the bearing to the drivetrain for proper fitting. This will allow for proper rotation and maximum power transfer/generation while providing a reaction force onto the drivetrain to allow for survivability at high wind speeds. The bearings will be expecting both radial and axial loads from the rotating drivetrain and active pitching system, respectively. These loads will be tested upon implementation onto the wind turbine, to give the most accurate results. Once the whole wind turbine is tested, the bearings will be inspected for signs of any failure modes. If there are signs of failure, then more durable bearings will be selected and the implementation testing will be repeated.

2.3.4 Generator

For initial generator testing, extensive testing was done in Simulink to determine how different generators would perform under the range of wind speeds specified for the competition. Rotational velocity was inputted to the generator block, which was calculated by using the given range of wind speeds and the tip speed ratio of the blades. The simulation would then show the voltage, current, and torque being output from the generator as a function of time so that an optimal generator could be chosen based on the desired specifications and output values. Once the generator is acquired, physical tests will be conducted on it using a dynamometer to determine the exact voltage, current, and torque it puts out at varying wind speeds up to 22m/s to simulate the conditions it will be placed under during the competition.

2.3.5 DC-DC Converter

To test the DC-DC converter we created a variety of simulations to test how the converter performs under different circumstances. After we ran simulations, we ordered the components so that we can build a prototype. The prototype was created on a breadboard where we can easily test and remove parts if necessary. The goal of the prototype testing was to prove that the converter can take in a range of input voltages from 0.5V to 3V from the rectifier and maintain a constant 5V output at the PCC by adjusting the duty cycle.

2.3.6 PCB

There are four steps to test the PCB. A bread-board with all the through hole mount components will be soldering on the board for the testing. Due to the size is pretty small, the surface mount components cannot be used into the bread-board. Once the testing successfully. The Altium Designer is a software that will be used to create the PCB layout, which we will use to create the PCB prototype. The electrical components will be soldered onto the PCB, and then an oscilloscope will be used to detect the output values and wavelengths to determine whether they're correct based on our inputs. The prototype will then be sent to a professional manufacturer to create a final PCB that we will use for the final wind turbine design.

2.4 House of Quality (HoQ)

A House of Quality (HoQ) was created from the customer requirements and engineering requirements specified from the previous two sections. The customer requirements' importance was weighted on a scale from 1-5 (with 5 being the highest importance). The engineering requirements relations to the customer requirements were weighted on a 0-1-3-9 scale (with 9 being the highest relation), and technical

requirement targets at the bottom of the HoQ were targets for each engineering requirement. Note that there wasn't a target value for every engineering requirement, as the target of some engineering requirements were arbitrary or different for each component we work with. The absolute technical importance (ATI) was then calculated as:

$$ATI = \sum_{i=1}^n [(CR Weight)_i * (ER Weight)] \quad (1)$$

Based on the ATI, the relative technical importance (RTI) at the bottom of the HoQ displays the most important engineering requirements (one being the most important). Table 3 shows a partial HoQ, but the full HoQ can be found in Appendix A.

Table 3: Partial House of Qualities

Customer Needs	Customer Weights	Engineering Requirements				
		Survivability Wind Speed (m/s)	Fit in 45cm by 45cm cube	Fit in 61cm by 122cm Turbine Door	Electric Housing (#)	Wire and Jacket Length from Turbine Base (m)
Power Generation	4.5	9	9	9	3	9
Electrical Grounding	1.0	0	0	0	9	9
Electric Wire Distribution	2.6	0	1	1	9	9
Transportability	4.0	3	9	9	3	3
Assembly	4.2	3	9	9	9	3
User Friendly	3.0	1	9	9	9	1
Safety	2.0	9	0	0	9	9
Durability	4.8	9	3	3	3	1
Maintenance	3.9	9	3	3	9	3
Aesthetics	2.7	1	1	1	3	1
Material Resources	3.6	9	9	9	9	1
Technical Requirement Targets Tolerance	0.5	-0.5cm	-0.5cm	Y	+0.2m	
Technical Requirement Targets	22	Fit	Fit	≥NEMA 1	1m (2x), 2m	
Absolute Technical Importance	200	205	205	231	141	
Relative Technical Importance						
Testing Procedure (TP#)	N/A	N/A	N/A	N/A	N/A	

3 EXISTING DESIGNS

The existing designs that were researched on pertain to the components relevant to this report. The components were: the blades, drivetrain, bearings, generator, DC-DC converter, and PCB. These components were sections of an overall wind turbine system that works in unison to produce electrical energy from rotational mechanical energy produced by the fluid wind speed energy. The blades translate the wind speed energy into mechanical energy, while the drivetrain transfers the mechanical energy into electrical energy through a generator. Then the DC-DC converter safely steps up the generator electrical energy to produce the necessary power by the overall system. The PCB is the bed that holds all electronics while providing a path for electronic transfer (when needed).

3.1 Design Research

Since Test Team A works on certain components of the overall turbine, research was done on only the components associated with Test Team A (the blades, drivetrain, bearings, generator, DC-DC converter, and PCB board).

3.1.1 Blades

When looking at the turbine blades, the airfoils that are being used have a big impact on the blades performance. There are several different companies that have developed airfoils and have released the specifications for how they perform. The National Advisory Committee of Aeronautics (NACA) and the National Renewable Energy Laboratory (NREL) are biggest companies that design airfoils. The NACA 4-digit series is widely used for its simplicity in generating new airfoils. The 4-digits are represented in groups, the last two digits, first digit, and the second digit. The last two digits represent the maximum thickness of the airfoil as a percentage. The first digit represents the maximum camber of the airfoil as a percentage from 0 to 9%. The second digit is an indication of where the maximum camber is in tenths of a percent (0% to 90% in steps of 10%) [4]. The NREL series are a harder to visualize but they break up different airfoils into airfoil families. There are many other airfoils that are available for low Reynold's number (Re) flows that we will be looking at when it is time to select airfoils.

3.1.2 Drivetrain

The research for the shaft consisted of looking through information provided in past NAU CWC team reports and the *Shigley's Mechanical Engineering Design* textbook. The 2016 design didn't have a drivetrain, so they had to connect the blade hub to the generator directly. The 2017 team machined their own direct drive shaft design for the drivetrain out of Aluminum 7075 material, which connected the wind turbine rotor to the generator while holding a gear that acted as a disk brake. Another design that was considered were gearboxes, which uses a gear system to increase the RPMs entering the generator to increase the power output [5].

3.1.3 Bearings

Different bearing types are useful for different loading and situational applications. The 2016 NAU CWC team's bearing selection process isn't in-depth, so the research conducted for the bearings come from the *Shigley's Mechanical Engineering Design* textbook. The bearings must withstand both radial and thrust loads from the wind turbine for a short number of hours (10 hours maximum). The selected bearings must have a static outer ring that is connected to the housing. There must be a inner ring that rolls the drivetrain with rollers (or balls) between the inner and outer ring. The bearing roller types dictate how well the bearings handle radial and axial (thrust) loads [5].

3.1.4 Generator

One of the power electronics components that our team has to build is the generator. There are several different types of generators that can be used for this project, and all of them have different pros and cons. The main types of generators that were researched for this project were a permanent magnet AC generator, a DC generator, or a rewired AC generator that we would optimize for this project.

The first design, permanent magnet AC generator, is the simplest of the 3. It works by turning magnets around fixed coils of magnet wire. The alternating north and south poles of the magnets induce an alternating current in the wire, which can then be sent to our rectifier. For the permanent magnet generator, the advantages are that we can get a good power output and keep the generator size small. This is also the kind of generator that has been used by almost every other CWC team, so it is well established and reliable. The drawbacks are that we get a low voltage output because of the fairly high KV rating (RPM/V) from this type of generator [6].

A DC generator also works by inducing current in coils of magnet wire, but the way it does it is different. In a DC generator, the coils rotate in a fixed field. The coils are attached to a commutator, which balances the charges coming into and going out of the generator, resulting in a direct current output. The advantages of a DC generator are that it eliminates the need for a rectifier and can be built fairly easily. The disadvantages are that it is larger, requires more maintenance, and is less efficient than its AC counterpart [6].

A rewired AC generator is something we would create for this project, where we would take an AC generator apart and then try to put it back together with thinner gauge wire, which would allow us to decrease our KV rating, therefore increasing our voltage output. The advantages of a rewired AC generator are the same as the normal AC generator, with the bonus that we can get more voltage out of it since we are rewiring it to optimize it for this project. The disadvantage of doing this is that it will take a lot of careful work and if a mistake is made in the rewiring process it could ruin the generator and we would have to get a new one.

3.1.5 DC-DC Converter

An important part of the turbine design is the power electronics. Our team has been assigned the task of designing the DC-DC converter. The purpose of the DC-DC converter will be to boost the output voltage of the system. There are various types of boost converters, all with specific advantages and disadvantages. As part of the research, we have looked at previous DC-DC converters used by past CWC teams. The 2017 Northern Arizona University team utilized a standard boost converter topology in their converter. Along with analyzing previous devices, we have researched several different types of converters. Performing simulations has helped to design and optimize the DC-DC converter to best fit the wind turbine. The simulations have been conducted in the Simulink software package and has required to learn the program. This has required us to watch tutorials on designing schematics in Simulink.

3.1.6 PCB

The *PCB Design Tutorial* textbook describes how to choose different types of PCBs and lays out the advantages and disadvantages in the various designs [7]. According to the customer requirements and engineering requirements, the board must be durable while minimizing the overall component cost. The four types of PCBs that will be analyzed for this report are: single-side boards, double-side boards, multi-layer boards, and bread boards. The pros and cons of these designs will be mentioned in subsequent PCB sections.

3.2 System Level

The component work in which we were undertaking contributes to an overall small-scale wind turbine that will be tested within a wind tunnel. In other words, the overall system of a wind turbine can be constructed in multiple ways based on the subsystem components. The existing subsystems' that we were assigned to work on are in the subsequent 3.2 sections.

A bigger-scale but similar type of wind turbine that exhibits the relativity and applicability of our project is the GE 1.5MW Wind Turbine. The GE 1.5MW Wind Turbine is a HAWT that includes the subsystems like our assigned subsystems: the blades, main shaft/gearbox, generator, converter, and board for electronics. This wind turbine is being implemented into various grid networks to continue to increase the wind energy production of the planet [8].

A smaller-scale home wind turbine that exhibits the relativity and applicability of our project is the 400-Watt Wind Turbine Power Generator for 12-Volt Systems from Home Depot. It's a HAWT wind turbine with three blades that customers can use "in their own back yard" for necessary energy applications. It has all the similar components as the turbine in which we are building. It can charge batteries, be used with an inverter to produce power for applicable electronics (like a T.V., lights, and/or power tools) [9].

Another small-scale wind turbine that exhibits the relativity and applicability of our project is the Primus Wind Power Air 40 12 Volt DC Turbine from Northern Arizona Wind & Sun. It is a three blade HAWT that works in "medium to high wind environments [10]." It too has similar components to the turbine in which we are building.

3.2.1 Subsystem Level: Blades

The blades of wind turbine are used to convert linear momentum of the wind into rotational energy of the shaft. The purpose of the blades is to generate lift causing the blades to rotate around the shaft axis. The blades are made up of different airfoils that are designed to work at different sections of the blade. The air foils need to be matched with the Reynolds number that the blade is operating at. This is important because each airfoil is designed to operate at a certain section of the airfoil and at certain Reynolds number ranges. The blades are a vital component because without them the turbine would be a giant pole in the ground.

3.2.1.1 Existing Design: Blade Material

Many of the current wind turbines for the DOE CWC have been made of carbon fiber and some type of 3-D printed material. The difference between carbon fiber and 3-D printed materials is the strength of material. Carbon fiber has mainly been used when deflection of the turbine's blades needed to be minimized and fewer number of blades were needed. 3-D printed material on the other hand were used when costs need to be low or a large number of blades were needed to be made. The application of material selection is important for the performance of the turbine. The material also greatly affects what type of airfoils that we can use. With the carbon fiber thinner airfoils are possible because molds are being used to form the blades. While thicker airfoils need to be used if the material is 3-D printed. During the 3-D printing process the tip resolution can only be so good, meaning the blade's design has to be something that the printer can handle meaning thicker airfoils.

3.2.1.2 Existing Design: Blade Types

When looking at the blade of a wind turbine the airfoils at the root (base) and tip of the blade are going to be different. In past years the teams have used the NACA 4-digit series airfoils. The reason that this series has been used is because it is easy to visually see what the airfoil is going to look like. The airfoils that are being used for the blades of the generally represent high lift airfoils. These airfoils are used for the lift that they create. The use of flat plates are not used for the turbine blades, however they are used for the tail fin.

3.2.2 Subsystem Level: Drivetrain

The two types of drivetrains that were analyzed: a gearbox and a direct drive shaft. The material of the shaft dictates its overall life based on geometrical constraints and the relevant loading factors. The necessary power requirements and the rotor RPMs dictated what type of shaft that used for rotational mechanical energy transfer from the rotor to the generator. The material of the disk brake dictated the weight of the gear and how well the brake will work (based on the braking friction).

3.2.2.1 Existing Design: Gearbox

A gearbox is a set of connected gears within a housing whose primary function is to increase the drivetrain's RPM speed. The connected gears differ in size (with the smaller gear, or pinion, as the driven gear) to increase the RPM speed. The usage of a gearbox would need a more in-depth analysis on the overall drivetrain system fatigue (as the possibilities of failure are much higher) [5].

3.2.2.2 Existing Design: Direct Drive Shaft

A direct drive shaft connects two rotating components directly [5]. On the wind turbine, a direct drive shaft would connect the rotor and the generator. With this design, the design analysis would be much simpler and there would be a lower failure probability. Nonetheless, the RPMs going into the generator would decrease, thus decreasing the power output.

3.2.3 Subsystem Level: Bearings

The bearings allow the drivetrain to freely rotate while staying in static equilibrium, transferring mechanical rotational energy as efficiently as needed. The bearing housing (attached to the nacelle and/or tower) and the bearing outer ring must be connected statically. There must be rollers or balls between the outer ring and inner ring (chosen based on load applications). The inner ring will be touching the drivetrain in analysis, allowing it to roll as freely as possible. Based on cost, availability and application location, the bearing types at different locations may change.

3.2.3.1 Existing Design: Single-Row Deep-Groove Ball Bearings

Single-row deep-groove ball bearings have deep raceway grooves with the inner and outer rings having circular arcs of slightly larger radius than the rolling balls. They work well with high speeds and radial loads. They can handle axial loads acceptably while having low torque capacity at startup and running speeds without requiring much maintenance. Based on the application needed of the ball bearings, different numerical series can be chosen [11].

3.2.3.2 Existing Design: Tapered Roller Bearings

Tapered roller bearings are composed of the cone (inner ring), the tapered rollers, the cup (outer ring), and a cage to retain the rollers. The loads on the bearing are carried by the cone, rollers, and cup. Tapered roller bearings are good for dimensional stability, a long life, and a very durable design (they can hold all loading types very well) [12]. However, the durable design comes at a higher cost. Locations for in need of a more durable design can use tapered roller bearings.

3.2.4 Subsystem Level: Generator

The generator is what converts the mechanical energy of the blades into usable electrical energy. It does this by rotating magnets around several tightly wound coils of magnet wire. This induces a current in the wire, which can be either AC or DC based on the type of generator and the components inside of it. This voltage is then fed into our rectifier (if AC) or directly into or DC-DC converter (if DC).

3.2.4.1 Existing Design: Permanent Magnet Synchronous Generator

This type of generator is much like the AC generator, but instead of the magnets rotating around the coils, the coils instead rotate inside a fixed field. The coils are then attached to a commutator, which gives a DC

output. The advantages of this are that it directly produces DC current so we don't have to convert it with a rectifier. The downside is that DC generators are less efficient, larger, and require more maintenance.

3.2.4.2 Existing Design: DC Generator

This type of generator is much like the AC generator, but instead of the magnets rotating around the coils, the coils instead rotate inside a fixed field. The coils are then attached to a commutator, which gives a DC output. The advantages of this are that it directly produces DC current so we don't have to convert it with a rectifier. The downside is that DC generators are less efficient, larger, and require more maintenance.

3.2.4.3 Existing Design: Rewired AC Generator

This design is just a modified version of the fixed magnet AC generator. We would take an AC generator and take the current coils out so we could put new ones in with a thinner gauge wire. This would increase the number of turns which would increase our voltage. It would also take a lot of time and effort on our part though and there is no guarantee that it would significantly increase our voltage.

3.2.5 Subsystem Level: DC-DC Converter

The main purpose of the DC-DC converter is to step the input voltage up to around 48 volts. In order, to do this the system utilizes inductors, capacitors, transistors and other electrical components to achieve a higher output voltage.

3.2.5.1 Existing Design: Boost Converter

A boost converter is a simple DC-DC converter that steps up the voltage through an inductor, capacitor, MOSFET and a diode. The device would function as a switch mode supply to step the voltage up.

3.2.5.2 Existing Design: Interleaved Boost Converter

This circuit is a more complicated form, of a boost converter. It is often called a multichannel converter as it contains to channels of inductors and MOSFET's operating 180 degrees out of phase. It has a high efficiency and requires more components than a boost converter.

3.2.5.3 Existing Design: Buck-Boost Converter

This design is another variant of a boost converter, it contains additional diodes and is a bit more complicated. The overall operating principle is the same with an added feature. When the pulse width of the MOSFET transistor is below 50% it operates as a buck converter. This device would provide the ability to either step the voltage up or down based off the pulse width.

3.2.6 Subsystem Level: Printed Circuit Board (PCB)

A printed circuit board (PCB) is a carrier that connects electronic software and hardware. It is a device that needs high precision and high reliability. It is an important part in a wind turbine electrical system, because when we design and test a circuit, we need to make our circuit into a board so that we can connect generator to the DC-DC converter and all other electronics.

3.2.6.1 Existing Design: Single-Side Board

Single-side board is a very common PCB board design. Some factories use the single side boards to design some circuits within televisions (TVs) and digital versatile disc (DVD) players. Single-side boards can be obtained at a relatively low cost. However, there are many constraints on components' placement when using single-side boards, as there is a limited amount of space [7].

3.2.6.2 Existing Design: Double-Side Board

Double-side boards allows for an extra layer that electrical components can be placed on. However, the area of the board is usually smaller than that of a single-side board, because there are more tiny chip capacitors and resistors that are in use within the circuit. These chip capacitors are only used on the bottom

layer to improve the circuit efficiency and reduce the error [7]. The cost of a double-side board is more than that of a single-side board, but it may be worth the extra area.

3.2.6.3 Existing Design: Multi-layer Board

There are four layers for a multi-layer board circuit design. There is the top layer, the bottom layer, the VCC layer, and GND layer. This design has the most complex circuit design out of the boards analyzed in this report, because we need to use single layer to put the VCC and GND. The usage of a multi-layer board will improve the electrical efficiency [7]. However, there is much more work associated with this design and the cost is more expensive than other board types.

3.2.6.4 Existing Design: BreadBoard

A breadboard is the simplest type of board in analysis within this report. It can be directly connected to the circuit. A bread board has many holes that can be directly used, but this design will increase the line resistance and decrease the output voltage. The control theory connection is very easy, because the circuit and the control can be connected [7]. The usage of the bread board is simple, but it comes at the cost of low efficiency.

3.3 Functional Decomposition

The functional decomposition for this project can be found in APPENDIX B: Functional Decomposition, as it was a large decomposition of the wind turbine into the main components. Within the functional decomposition the different components of the turbine have been broken down into analytical terms. It also contains possible design choices that come along with each component. As shown in the functional decomposition, the main sections of the wind turbine include the power electronics (DC-DC converter and rectifier), the load (capacitor bank and batteries), the generator (AC/DC Generator), and the mechanical structure (blades, hub, shaft, yawing, nacelle, and tower). The components that this report refers to are: the blades, the shaft, the generator and the DC-DC converter.

3.3.1 Black Box Model

The wind turbine black box model shown in Figure 1 displays the necessary material, energy, and signal inputs with their corresponding outputs to translate mechanical energy into electrical energy on a wind turbine. The inputs necessary include the wind speed and direction which rotates the rotors (translating wind energy into mechanical energy) and a start, break, and stop feature for applications of these signals before and/or during operation. Then, mechanical energy is translated into electrical energy through a shaft and generator design that produces electricity and a DC-DC converter that steps up the electrical energy. The signaling output for a working turbine shows the rotor spinning and allows for working electronics when the wind turbine is on, while the rotor would be stationary, and the electronics wouldn't work when it's off. The black box model helped our team understand the major material, energy, and signals associated with completing our overall goal. The necessary inputs were the building blocks of our components' functionality, while the outputs were the goals each component must work toward for proper wind turbine functionality.

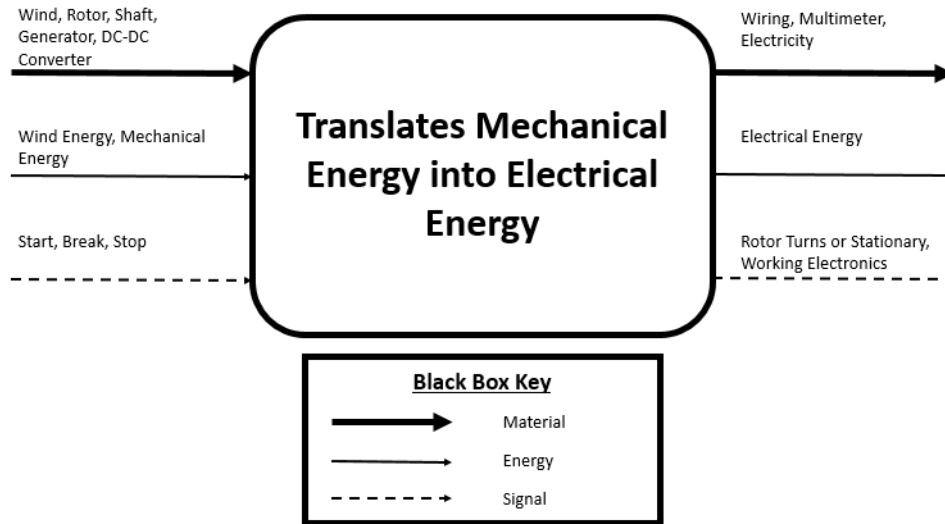

Figure 1: Wind Turbine Black Box Model

3.3.2 Functional Flow Model/Gantt Chart

The functional model that is shown in Figure 2 displays what was required of the components referred to in this report. The wind flow speed is caught by the blades, which then creates kinetic rotational energy by spinning the rotor which is connected to the drivetrain. The drivetrain's kinetic rotational energy is then translated into an electrical power signal through a generator that is connected electronically to a DC-DC (boost) converter. The boost converter (which is connected to a PCB) then steps up the voltage that flows into the electrical grid.

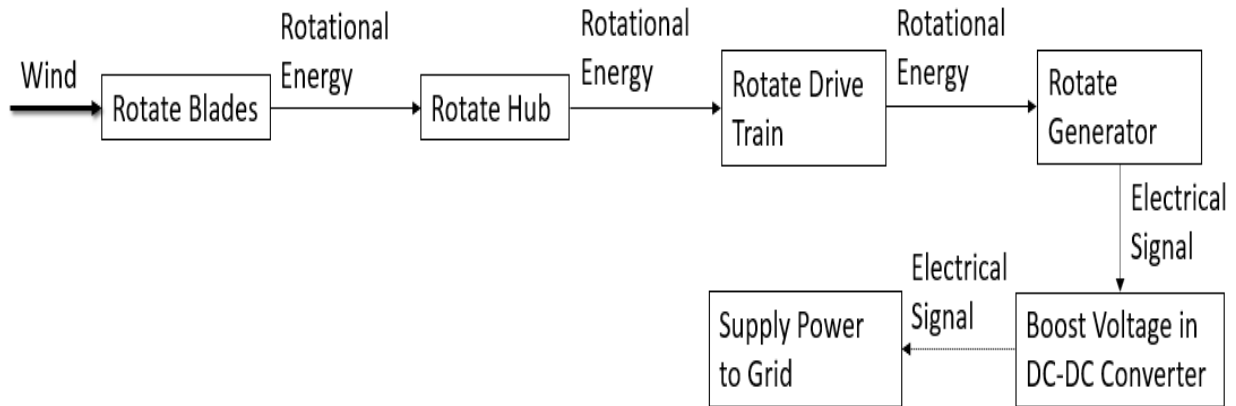

Figure 2: Functional Flow Model

Appendix C shows the Gantt Chart of the entire collegiate wind competition team. Within the headings were each teams' deliverables and a timeline for completion. Test Team A's deliverables for the upcoming 2018 term is displayed in Appendix C. The deliverables mainly consist of determining materials, ordering the materials, testing the materials, then assembling the materials on the overall wind turbine that will then be tested before the CWC in May. This Gantt chart helped us clarify our timeline to complete necessary deliverables in a timely manner.

4 DESIGNS CONSIDERED

The following sections pertain to the considered component designs for the blades, drivetrain, generator, DC-DC converter, and PCB board.

4.1 Blades

By generating different ideas than those that have been used by existing ideas. The benefits of coming up with new ideas for the blades it is possible come up with a design that can generate more power or be more efficient.

Through the concept generation process many designs were created to increase either the performance, power, or efficiency of the blades. The first concept (shown in Figure 3) that was created was to try to increase the Reynolds number (Re) that the blades are acting at. By increasing the Re there is a larger selection of airfoils that would be able to use. Therefore, potentially increasing the power generated for the turbine's.

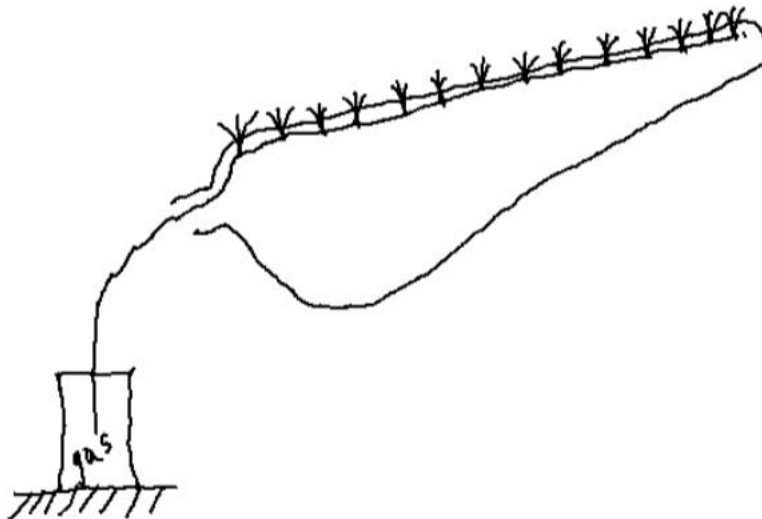

Figure 3: Fluid Nozzles to Increase Reynolds Number

The second design created (shown in Figure 4) was a telescoping blade. The purpose of design was to be within the size restriction of the competition, but once the blade starts rotation and the centripetal force increase the length of the blade increase the torque of the turbine, increasing the amount of power that can be produced. Since there are a lot of forces on the turbine blades this design would need a lot of analysis to determine if the blades would survive under all the stress at higher wind speeds.

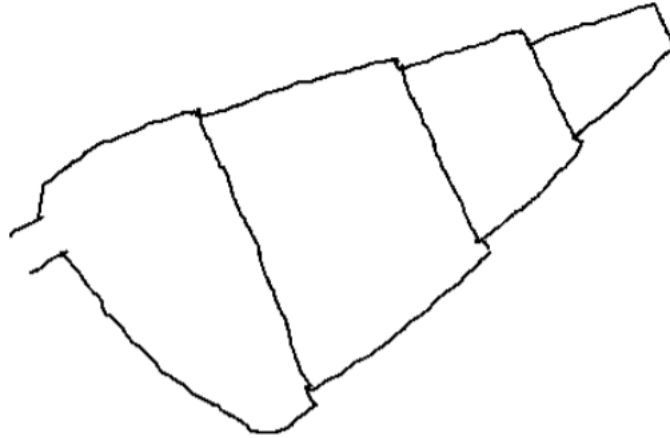

Figure 4: Telescoping Blade

The next design (shown in Figure 5) is a blade that is curved. The reason for the curve on the blade is to decrease the noise that is produced at higher RPMs of the turbine blades. While reducing noise it increases the tip losses. With the increased tip loss, the performance of the turbine would decrease and be less efficient. However, because of the shape of blades it would have an appealing factor that customers might like.



Figure 5: Curved Blade

Another design that was taken from an automotive application is the use of a shroud (shown in Figure 6). The use of the shroud would cut down on wake rotation. By cutting down on wake rotation it the blades would behave more like a betz blade. The shroud would also act as a small nozzle increase the velocity of the flow as it enters the upstream side of the blades. Since the power in the wind is equal to the curve of the velocity, the amount of power that the turbine can generate would be increased.

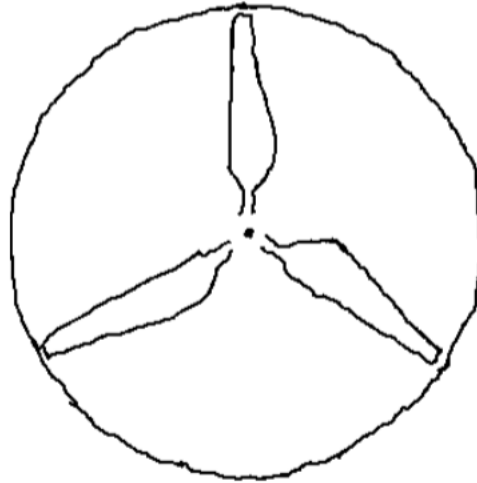

Figure 6: Blade with Shroud

A typical blade for a wind turbine (shown in Figure 7) is simple and does not require extra calculations to determine the amount of power that the turbine is producing. A normal design like this is the most commonly used. Figure 5 shows a typical blade design with a shroud around the turbine blades. The circle on the outside is a shroud to direct the air through the turbine as well as avoid send the flow in the radial direction. The shroud also has the added benefits of speeding up the flow as it goes around the shroud to hopefully match the velocity of the air on the back side of the turbine blades.

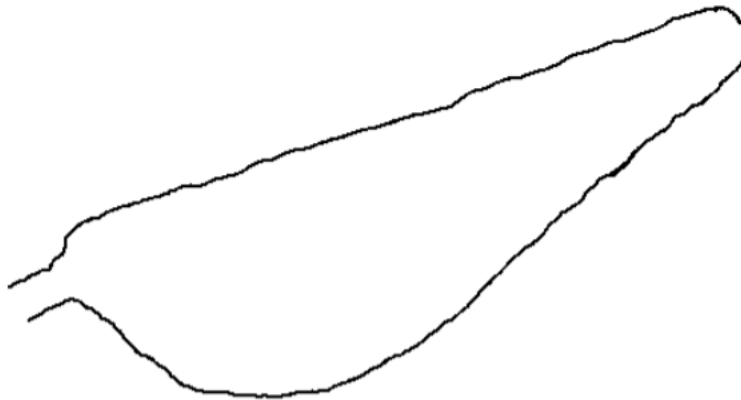

Figure 7: Conventional Blade

4.2 Drivetrain

There were two drivetrain designs in consideration: the gearbox drive and the direct drive shaft. One of these two designs was chosen as the drivetrain between the wind turbine rotor and generator based on needed power requirements and design difficulty. The material of the drivetrain will be iteratively analyzed and chosen based on relevant fatigue factors that are based on the drivetrain design decision.

A simple gearbox design is shown in **Error! Reference source not found.** The pros of the gearbox include: an increased amount of RPMs and an increased power output. The cons of a gearbox drive include: a higher probability of failure, more complications in the overall design, and a higher overall cost.

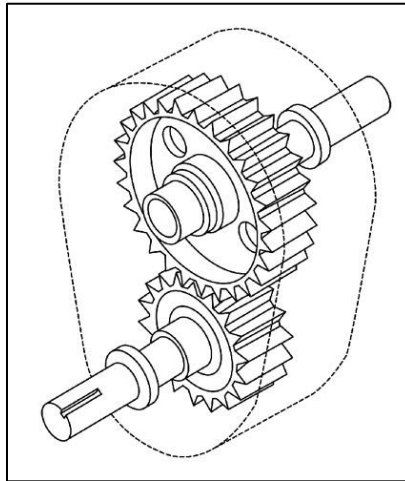

Figure 8. Gearbox Drivetrain [13]

A simple direct drive shaft is shown in Figure 9. The pros of the direct drive shaft include: a lower cost design, a higher safety reliability, and an easier design to work with. The cons of the direct drive shaft include: a lower amount of RPMs for the generator and less voltage production through the generator.

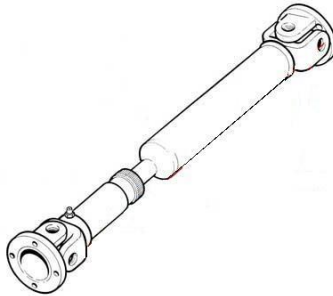

Figure 9: Direct Drive Shaft [14]

Based on the design choice: the material of the shaft has to be able to handle high loading factors from the rotor, generator, and disk brake. Therefore, the tensile strength and yield strength must be as high as possible. Aluminum is a relatively low cost metal with adequate strengths to handle the expected loads, which can be adequate for the wind turbine design.

4.3 Bearings

For the drivetrain mechanism, the bearings to be analyzed were single-row deep-groove ball bearings and tapered roller bearings (based on iterative geometrical constraints) that will be supplied by Applied Industrial Technologies®. Since there can be various application locations, either bearing may be used for each application based on the relevant loads and the overall bearing costs. Figure 10 displays a single-row deep-groove ball bearing design and Figure 11 displays a tapered roller bearing design, both from Applied Industrial Technologies® at a scale similar to what was expected for application into a small scale wind turbine.



Figure 10: Single-Row Deep-Groove Ball Bearing [15]



Figure 11: Tapered Roller Bearing [16]

On the drivetrain, the bearings must handle both axial and radial loads when closer to the rotor, while mainly only handling radial loads closer to the generator. The bearing near the rotor withstands most of the axial load; therefore, this location will take into consideration both bearing types. The bearings near the generator (or in any other location) were chosen as ball bearings, with the geometry chosen based on the iterative design process.

4.4 Generator

The first generator design we are considering is a permanent magnet synchronous AC generator. This type of generator is good because it is a simple design, small size, and provides reasonable voltage and power values for our competition. The drawbacks of this type of generator is that it requires a rectifier which adds another component to our design, and it also can't produce higher voltage values without producing a power value that is too high for the competition. Figure 12 is a Simulink model of a permanent magnet generator that has been used for testing this type of generator. This model would also be used for testing a rewired AC generator, with the specifications changing but the overall design remaining the same.

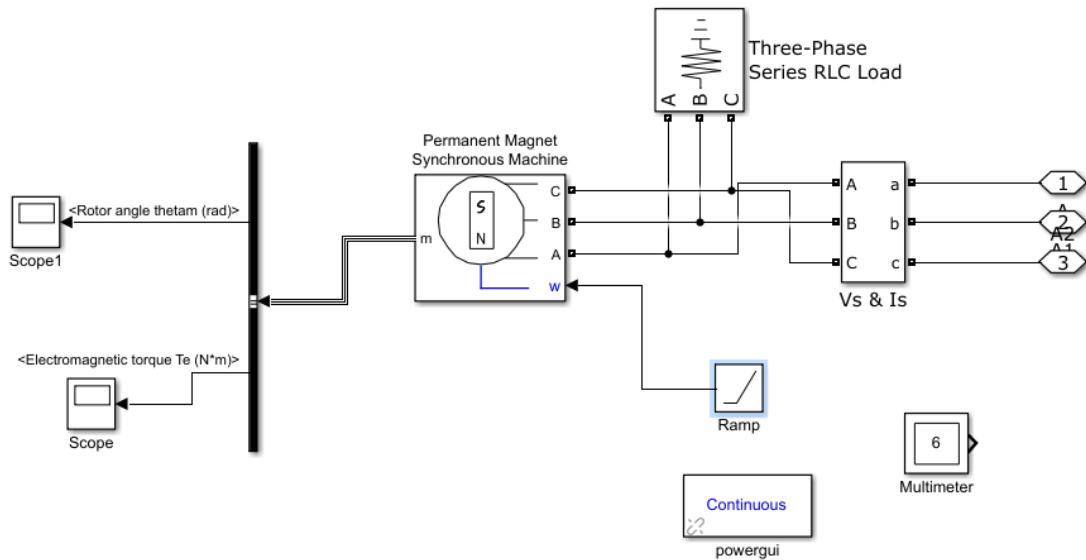

Figure 12: Simulink Generator Model

The other type of generator that was considered was a DC generator. This type of generator would eliminate the need for a rectifier, but would also be larger, less efficient, and less reliable than an AC generator. It would save us time because of not having to build a rectifier, but would not be ideal for the competition because our voltage and power values would not be as high. Figure 13 is a diagram showing a simple DC generator, with the coils rotating in a fixed field with a commutator fixing the voltage output.

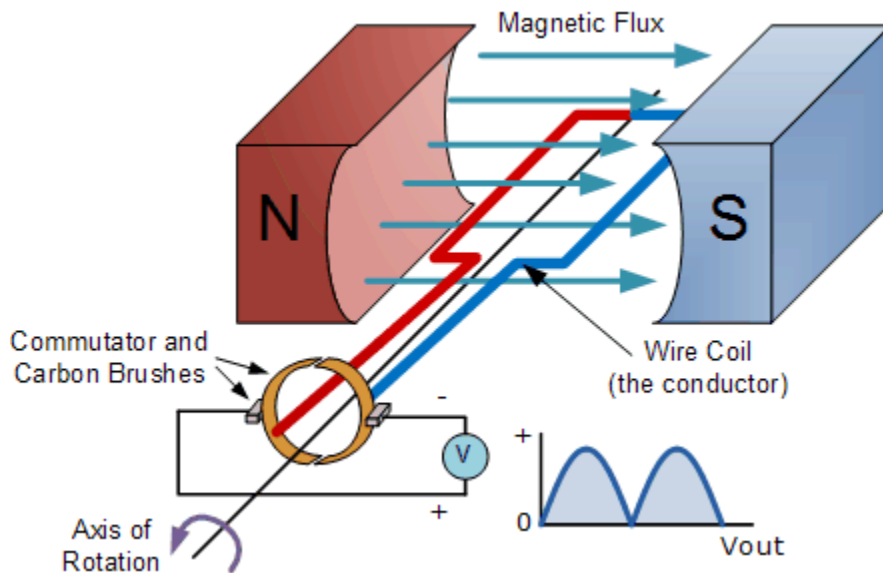

Figure 13: DC Generator [17]

4.5 DC-DC Converter

In order, to decide which type of DC-DC converter to utilize for our system, we conducted research to find which converter would best match the needs of our project. Ultimately, we came up with four different designs to consider: boost converter, interleaved boost converter, flyback converter and a buck-boost converter. Upon further research, we eliminated the flyback converter because of its difficulty to implement, and that it required a transformer. Also, with the equipment available to our team we would not be able to successfully build and test the converter. The buck-boost converter could be eliminated based on premise that our system would only need to step the voltage up and it would not be necessary to step down the voltage. This left two designs remaining, from there we built two Simulink models for each converter.

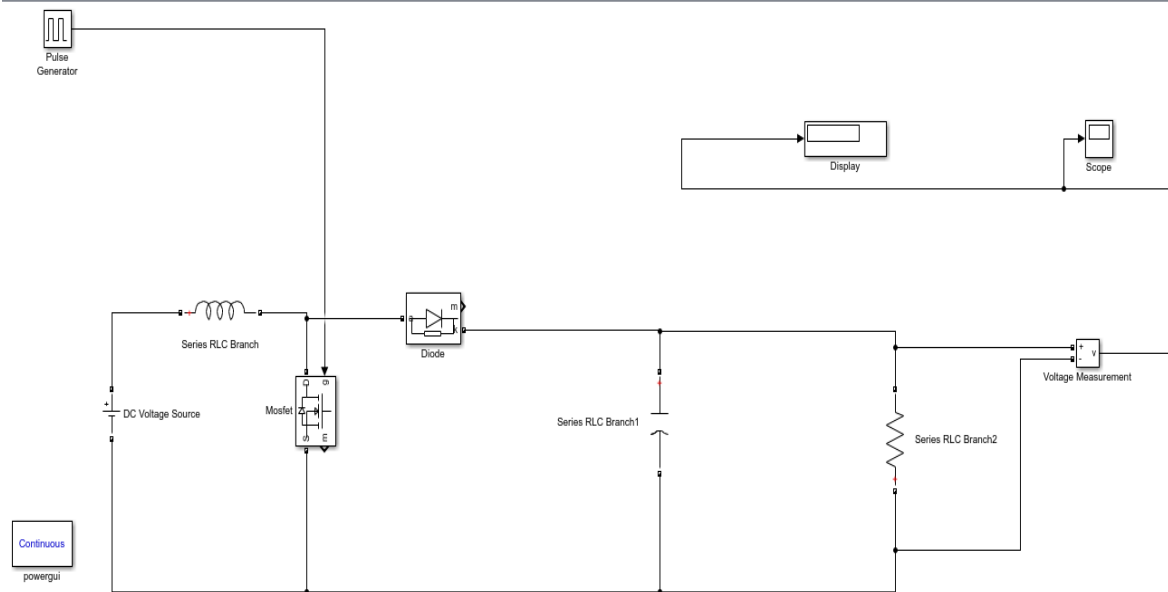

Figure 14: Boost Converter

Figure 14 is a schematic of a boost converter that was designed for the project. It is a simple design, which will make designing the converter relatively simple. However, it does not offer several of the advantages of an interleaved boost converter.

An interleaved boost converter or multi-channel boost converter, as seen in the schematic as shown in Figure 15 would require more components than a typical boost converter; however, we believe the advantages are well worth the extra effort to implement. By having a multi-channel converter, the overall efficiency of the system would be improved along with reduced voltage ripple and shrinking the inductor and capacitor size [18].

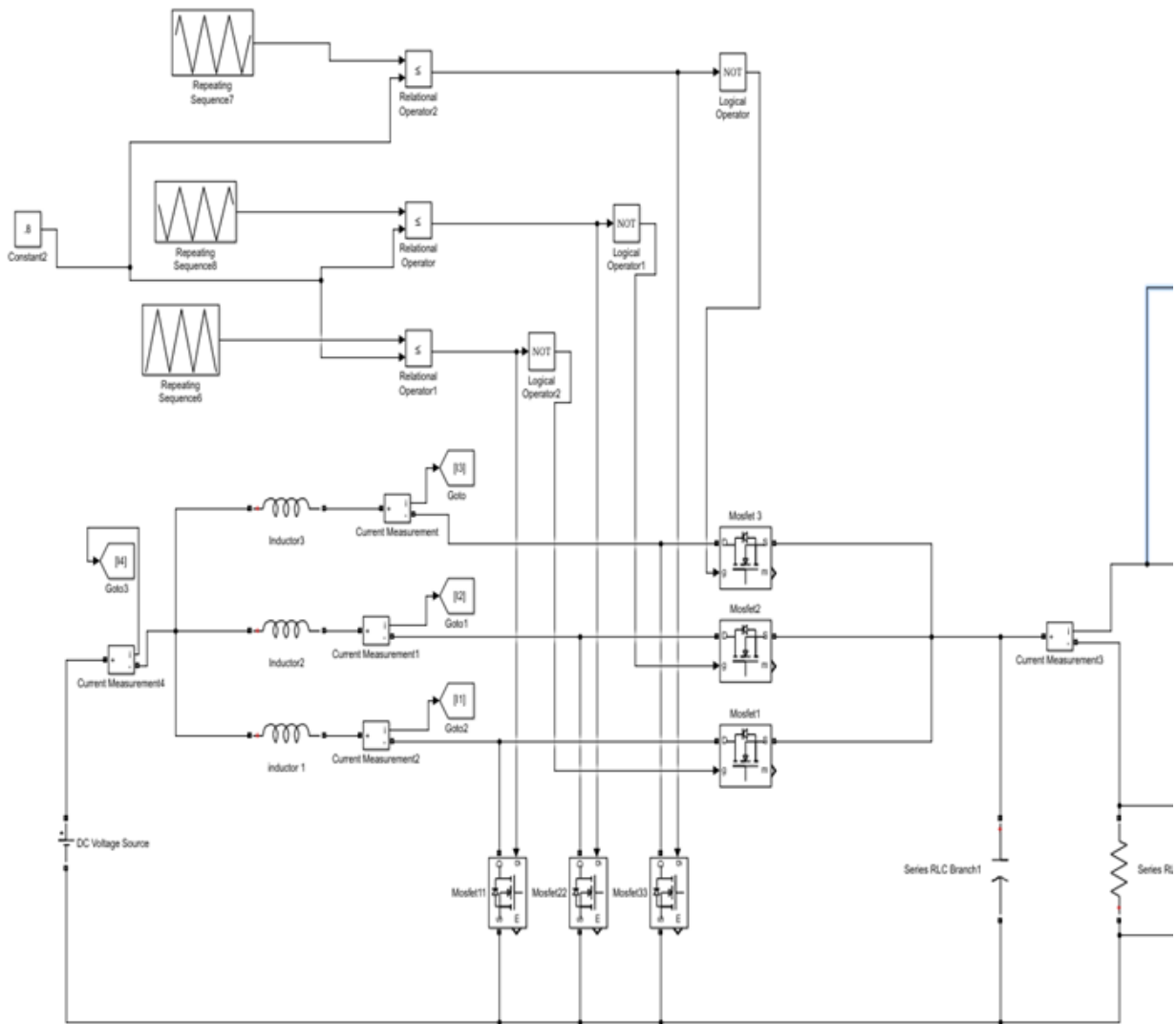

Figure 15: Interleaved Boost Converter

4.6 PCB

There are different types of wiring diagrams that can be used for this project, all with their own advantages and disadvantages. The simplest diagram is a single-side board shown in Figure 16. Single-side boards are easy to repair, but the lines we use to connect components cannot cross. Double-side boards shown in Figure 17 have larger area sizes to work with, as it can house electronics on both the top and bottom layers of the boards. However, double-side boards will increase the area of the wiring, as wires must connect the top and bottom layers, which will complicate the overall PCB design. Multi-layer boards shown in Figure 18 are the most complex boards within these design considerations; they are applied to more sophisticated circuit designs. Bread boards shown in Figure 19 are the simplest designs; however, they decrease the efficiency dramatically.

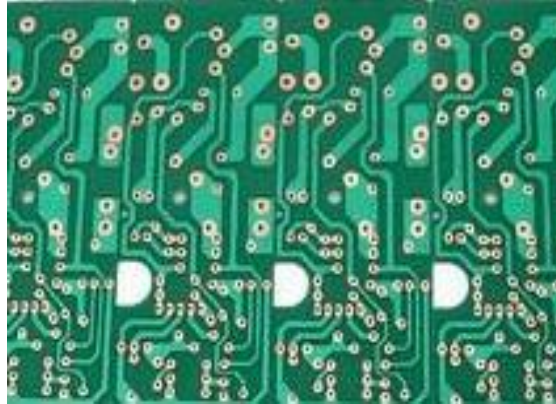

Figure 16: Single-Side Board

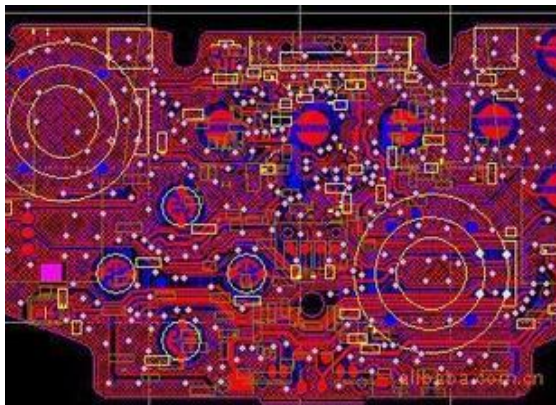

Figure 17: Double-Side Board

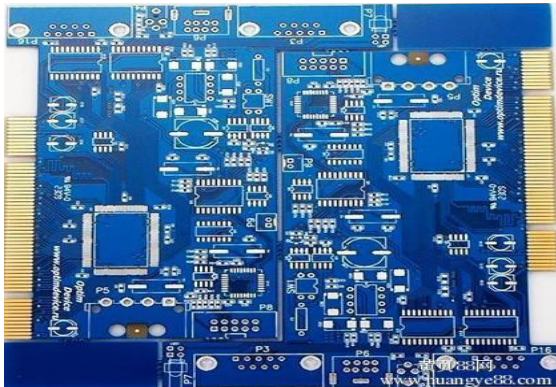

Figure 18: Multi-Layer Board

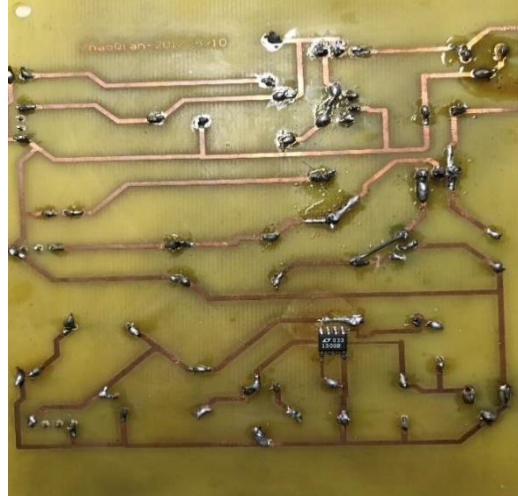

Figure 19: BreadBoard

5 DESIGN SELECTED

The overall wind turbine design selection was based on the assembly of selected individual components. The components relevant to this report were selected based on logic and with the help of decision matrices; each component was selected to improve the overall wind turbine design. The choices were: blades will be conventionally made, the drivetrain will be a direct drive shaft, all bearings will be single-row deep-groove ball bearings, the generator will be a permanent magnet synchronous AC generator, the DC-DC converter will be a 3-channel interleaved boost converter, and the PCB will be a double-layer board.

5.1 Rationale for Design Selection

5.1.1 Blades

After the concept generation stage of the design process, an initial design is needed to be selected. With blade design 2 and the blade length increasing, it pushes the blades outside the allowed area for the turbine; therefore, that design must be scrapped. With blade design 3, the amount of power that the turbine is going to produce, extra losses from the tip of the blades would be bad decision and would almost be impossible to recover from the losses this design. Therefore, this design was also scrapped to maximize the amount of power that the turbine can generate. After scraping blade designs 2 and 3, a closer look at how the manufacturing of the blades would occur was needed. The diameter of fluid pipe would be extremely small to fit within the thickness of the turbine blades. For this reason blade design 4 was also scrapped. After looking at the concepts that remain, design 5 (the conventional blade) is selected as the initial design for the simplicity and reliability of the blades at higher wind speeds. No decision matrix has been used for this design decision, because all other designs considered besides the conventional blade design is obviously not feasible.

5.1.2 Drivetrain

The drivetrain was designed to be a short direct drive shaft that directly connects the blades hub to the generator while providing a disk brake gear with different material. The direct drive shaft was less complicated and will have less factors for failure, while providing adequate rotational momentum transfer. Table 4 below displays the decision matrix used to come to our drivetrain decision. The direct drive shaft outscored the gearbox in all categories besides the functionality aspect, as the gearbox increases the revolutions per minute entering into the generator.

Table 4: Drivetrain Decision Matrix

Criteria	Weights	Direct drive shaft	Gearbox
Reliability	0.60	8	4
Size	0.05	8	6
Functionality	0.20	5	8
Ease of implementation	0.15	7	4
Total	1.00	7.25	4.9

5.1.3 Bearings

Single-row deep-groove ball bearings and tapered roller bearings both have their own advantages and disadvantages as stated in section 4.3 in this report. For simplicity, the bearing applications on the drivetrain and yaw mechanism were assumed to have all locations experiencing both radial and axial loads. Table 5 below displays the decision matrix used for rationale on which bearing type to use for both applications based on expected geometrical constraints. As it can be seen, they both have a very similar total rating due to the expected size of the applications. However, the single-row deep-groove ball bearings cost less (in general), so they will be chosen for both applications.

Table 5: Bearings for drivetrain and Yaw Mechanism Decision Matrix

Criteria	Weights	Single-Row Deep-Groove Ball Bearing	Tapered Roller Bearing
Reliability	0.60	8	9
Size	0.05	9	7
Functionality	0.20	8	7
Ease of implementation	0.15	9	7
Total	1.00	8.2	8.2

5.1.4 Generator

For this project, we have decided to use a rewired AC generator because it will give us the best voltage output compared to the other options. Even though it takes more time and effort and there are risks involved with it, we want to have the best possible generator for the competition and we believe this is the best way to get such a generator. When we put the options into our decision matrix, it gave the same result, which is that a rewired AC generator was the best option.

Table 6: Generator Decision Matrix

Criteria	Weights	Permanent Magnet AC	DC	Rewired AC
Reliability	0.60	7	4	5
Size	0.05	5	8	5
Functionality	0.20	9	6	4
Ease of Implementation	0.15	7	8	2
Total	1.00	7.3	5.2	4.35

5.1.5 DC-DC Converter

Our initial selection, we used a pairwise matrix and a decision matrix to help select which converter to go with. The weighting from the decision matrix is based off the values determined by the pairwise matrix. From the outcome of the decision matrix, we believe an interleaved boost converter, will best fit the scope of the project. An interleaved boost converter offers several advantages: improves efficiency, reduces ripple, and shrink capacitor and inductor sizes [13]. The criteria for the DC-DC converter matrices were:

1. Reliability: The final product will need to work a high percentage of the time.
2. Ease of Implementation: Developing the DC-DC converter will require a lot of work to design. Being able to limit this work could potentially save time.
3. Functionality: The functionality is very broad, and encompasses other important characteristics like voltage ripple and device efficiency.
4. Size: The team has a limited space that the device needs to fit into.

Furthermore, in Table 7, the scale that we are using goes from one to nine. Nine being the best that a criterion can achieve and one the lowest.

Table 7: DC-DC Converter Decision Matrix

Criteria	Weights	Boost Converter	Interleaved Boost Converter
Reliability	0.60	6	5
Size	0.05	6	5
Functionality	0.20	5	6
Ease of Implementation	0.15	7	6
Total	1.00	5.77	6.01

5.1.6 PCB

The electrical board area should be minimized to decrease cost and allow for needed electric systems. It should also be easily reliable, as replacements are needed in case of failure but should be minimized. The PCB also must have good functionality, as to also minimize PCB replacements. Table 8 displays the PCB decision matrix. As it can be seen, the double-side board is the best choice for a PCB, as it offers a good balance between reliability, size, functionality and the ease of implementation.

Table 8: PCB Decision Matrix

Criteria	Weights	Single-Side Board	Double-Side Board	Multi-Layer Board	Bread Board
Reliability	0.60	5	7	6	3
Size	0.05	3	6	7	2
Functionality	0.20	4	7	8	3
Ease of Implementation	0.15	7	6	3	8
Total	1.00	5	6.8	6	3.7

5.2 Design Description

In each components' respective section, the description of their design (which will be implemented into the overall wind turbine design) is given.

5.2.1 Blades

When working on specification for the blades there was a few requirements in the rules and regulations that had to be looked at. In the rules it states that the maximum entire hub must fit within a 45-cm x 45-cm x 45-cm cube. From this the maximum diameter of the wind turbine can be 45-cm. With a diameter of 45-cm the maximum blade length can be is 22.5 cm. However, this does not take into consideration the size of the hub. For the analysis and after talking another team member that is working on the hub and he needs the hub to be 6-cm in diameter. Taking this requirement into consideration the maximum length of the blades is 19.5-cm. With this length and the one-two-three equation with inputs (density, diameter, and mean wind speed) the absolute maximum power that can be generated from the turbine is 110W [3]. For that power output there are several assumptions that are being made including an ideal wind turbine, efficiency of 1, and Betz optimum blade.

For our design, we need to incorporate many factors that are not in the one-two-three equation such as tip losses, turbine efficiency, wake loss, and drag. Also, since our blades are smaller the Reynolds number that the blades are acting at are low and special airfoils need to be used to generate the required torque needed to turn the generator. The air foils that are needed for the Reynolds numbers range are high camber or single surface airfoils.

When analyzing the performance of the wind we used a MATLAB code to deliver the primary detentions for the blades, the next step is to import those blade into a Blade Element Momentum (BEM) code in

MATLAB. This code predicts the performance of the turbine with the outputs of Coefficient of Performance (CP) vs Tip Speed Ratio (TSR) and the axial induction factor and rotational induction factor. From this if the performance is close to what we are looking for, we can input the detentions and specs into Qblade. Qblade has more detailed outputs such as, power, CP vs TSR (can compare these graphs), torque vs Revolutions Per Minute (RPM), Coefficient of thrust vs TSR, power vs wind speed, and many more plots. The performance in Qblade is very graphical and not very numerical, so that the user can see how the turbine is going to change with slight variation of inputs. Table 9 is the information that is produced from the MATLAB code and is the required imports that Qblade needs. The units on the table are meters for the first two columns and degrees for the last three columns. This is also the first part of the blade design process that we can see what the blades/turbine as a whole. Figure 20 below is our current blade and Figure 21 shows the current rotor design. However, the results of our current blades shown in this section will change as the Re used in the analysis was done at 50000 where the actual Re is going to be lower.

Table 9: Outputs from MATLAB. First 3 columns are inputs for Qblade

r	C	Twist_Angle	Relative_wind	Section_pitch
0.0195	0.0627	36.357	39.357	29.357
0.039	0.058253	23.537	26.537	16.537
0.0585	0.046945	16.37	19.37	9.3697
0.078	0.038081	12.08	15.08	5.0799
0.0975	0.031678	9.29	12.29	2.29
0.117	0.026987	7.3494	10.349	0.34941
0.1365	0.023449	5.9283	8.9283	-1.0717
0.156	0.020702	4.8455	7.8455	-2.1545
0.1755	0.018516	3.9943	6.9943	-3.0057
0.195	0.016739	3.3082	6.3082	-3.6918

The current airfoils that are being used are the NACA 4410, 3508, and the 3308. These airfoils were used chosen because they are similar airfoils, had a high lift at this Re. For a turbine of this size it is important that airfoils are generating a large amount lift while keeping the flow attached to the airfoil, or have these airfoils act like larger/thicker ones. Since the Re needs to be lowed the airfoils that are being used will need to be changed and even more camber is going to be needed.

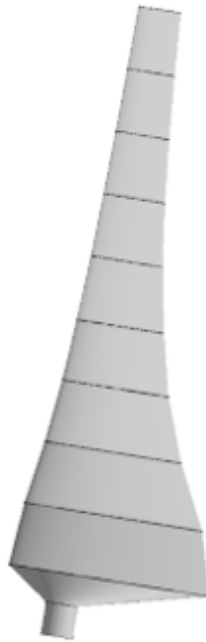

Figure 20: Current Blade Design

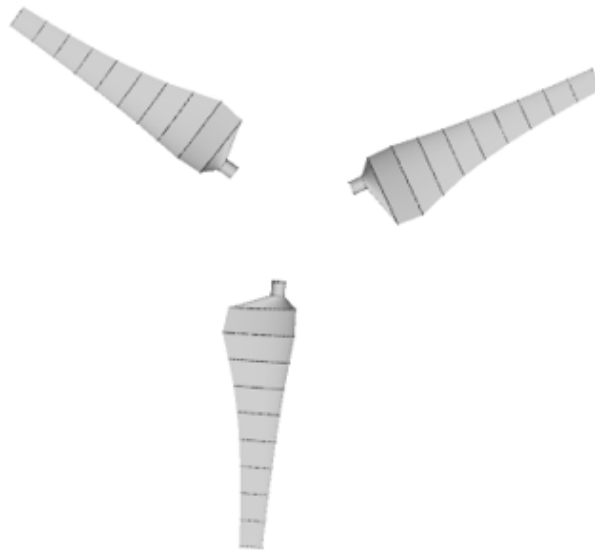

Figure 21: Current Rotor Design

With this current rotor design we can even look at the anticipated power that the rotors can produce. The main thing that should be looked at on this graph is the rated power which is the velocity of the wind that blades were designed, in this case at 10 m/s. According to Figure 22 at 10m/s the power is 21 W. Another area of this graph that needs to be questioned is what happens as the wind speed increase the power should eventually drop off.

The current thought on the material of the blades is to use a type of 3D printed martial. The current material that is being looked into is ULTEM 9085. This is because ULTEM can be printed in the rapid lab at NAU. The ULTEM 9085 has a tensile modulus of Elasticity of 2.15-2.27 GPa [14]. Since the blades are relatively small, they are going to have a higher force in the radial direction compared to any other direction. The density of the ULTEM 9085 is $1.34 \frac{g}{cm^3}$, and with the volume of the turbine blade of $16.5 cm^3$ makes the approximate weight of the blade 22.1 g [14].

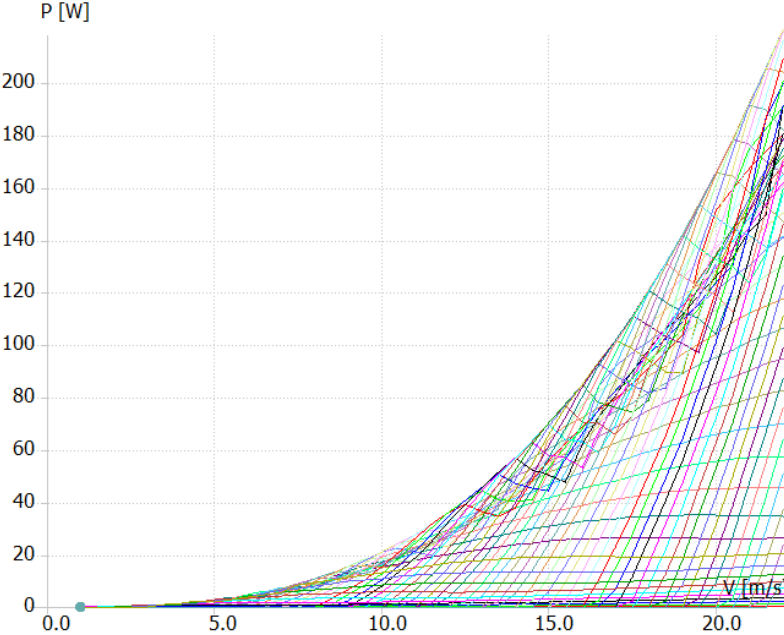

Figure 22: Power vs Wind Speed Graph

Shown below in Figure 23 is the current blade in solidworks. This blade has a been modified from what was done in Qblade because the root of the blade has been changed in order to accommodate the hub and pitching system.

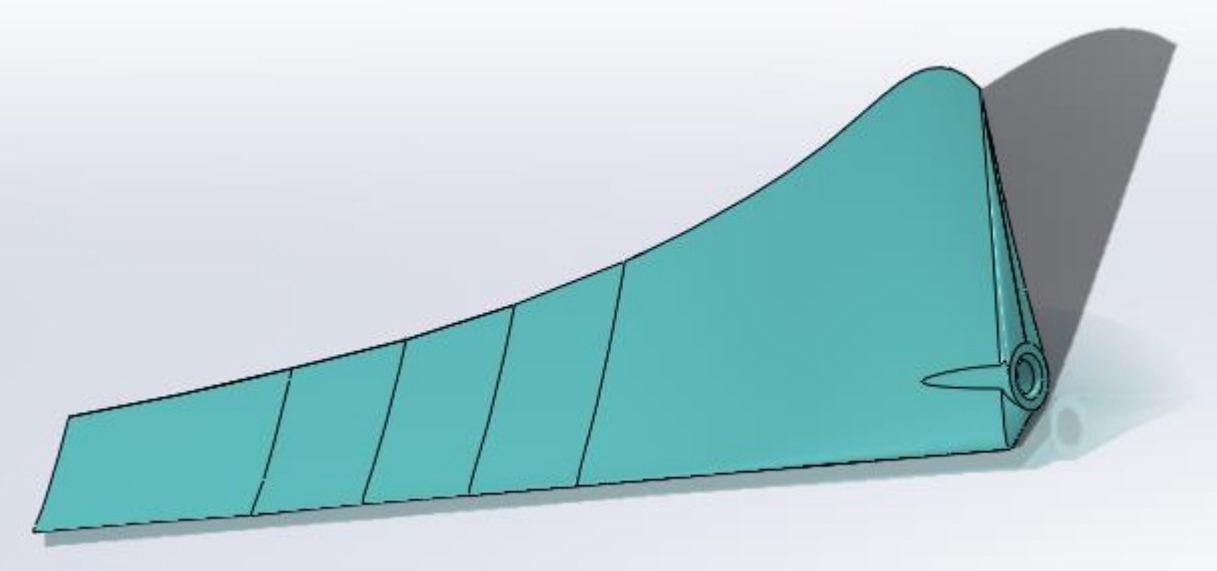

Figure 23: Current Blade in Solidworks

5.2.2 Drivetrain

The shaft that was used in this design was a direct drive shaft. The drivetrain connects the rotor to the generator transferring mechanical rotational energy to be converted to electrical energy. The shaft must be able to handle the torque loads from the rotor and the brake system while handling the weight of the hub without failure. Aluminum 7075 is a hard to repair material type; nonetheless, it was the best material type for this design as it has a relatively low cost for expected geometries, it was easy to machine and it has a low relative weight than other material types (for easier rotor yawing).

When compared to other Aluminum types, Aluminum 7075 has the highest yield strength (540 MPa) and ultimate tensile strength (593 MPa) that was suitable in handling a 5 Nm torque at the middle of the large diameter (location of the brake), and a 2.5 Nm torque and an expected weight of approximately 300 grams at the left end of the shaft (location of the rotor). Each expected load was chosen to be higher than expected to account for any manufacturing errors or unexpected loads. Shown in Appendix D is a MATLAB code that was created to calculate the fatigue factor of safety of the shaft based on the chosen geometry, material properties and expected loads. Figure 24 displays the CAD drawing geometry in millimeters (mm) of the direct drive shaft to be tested for our wind turbine design based on the MATLAB code to produce a factor of safety of 2.

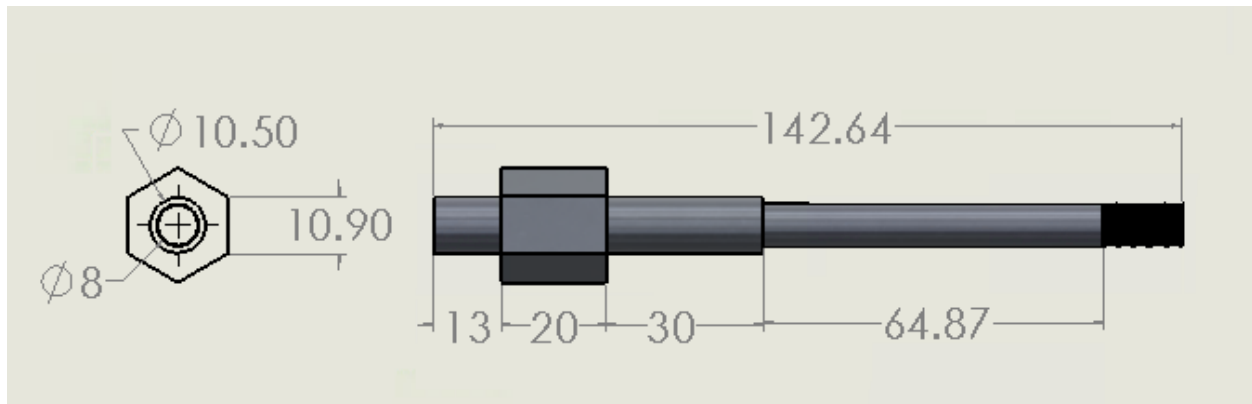

Figure 24: CAD model of the Direct Drive Shaft

5.2.3 Description: Bearings

The bearings chosen for applications on the drivetrain are single-row deep-groove ball bearings supplied by Applied Industrial Technologies®. This bearing type has the simplest design with the lowest relative cost. The bearing will be expecting (in the worst case scenario) a radial load of 5 N from the rotating shaft and an axial load of 25 N from active pitching mechanism. The expected loads are run through the Bearing Catalog Load Rating MatLab code shown in Appendix E. The catalog load rating produced from the MatLab codes helps with the decision of which specific bearing will be chosen with the given inner diameter of 8 mm. Figure 25 below shows a geometrical CAD drawing of a single-row deep-groove ball bearing that will be used for our bearing applications on the wind turbine.

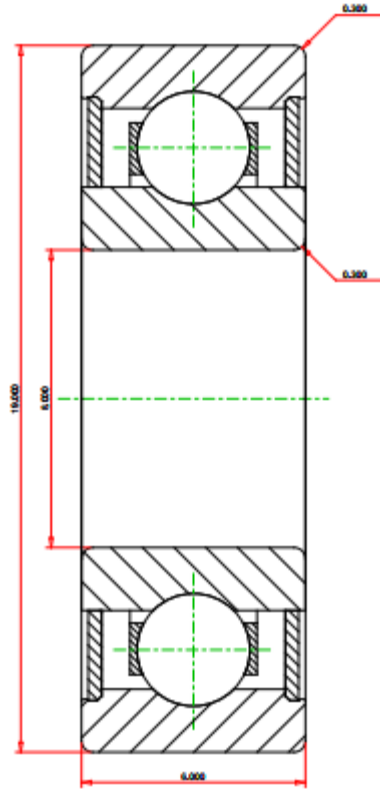

Figure 25: Timken Co. 619/8-2RS Single-Row Deep-Groove Ball Bearing Drawing [20]

5.2.4 Generator

For the original generator selection, we researched many different AC and DC generators with specifications similar to the ones needed for the project. Below is Table 10 of 10 AC and 5 DC generators with specifications that were researched for this project. All of them have KV ratings that will provide a voltage range of 0-10V, which is ideal for this project where the desired overall output voltage was 16V.

Table 10: Possible Generators

Part Number	KV Rating	Diameter Size (cm)
IF4114	320	N/A
MT4012	340	4.7
MN4012	340	4.0
P5012	360	N/A
ML3510	360	4.2
S5008	330	5.75
V4004	300	N/A
MN3510	360	3.5
D5010	360	5.0
ML3510S	360	N/A
0.60 Size Outrunner	380	5.0
X6210	380	6.2
X4108S	380	4.6

The final generator selection for this project was chosen to be the SunnySky X4108s. A picture of it is included below in Figure 26 for reference. This generator was chosen due to its good KV rating, small

size, and relatively low torque. Its KV rating allows it to put out 0-10V over the range of wind speeds specified for this project, which satisfies our power curve and rated wind speed performance criteria. Its size allows it to be easily mounted to the turbine without requiring any extra parts to be designed or built to accommodate for it. It also helps us easily satisfy our turbine size criteria. The low cogging torque due to large number of poles in the generator allows it to start spinning easily which means that the cut in wind speed for the turbine can be lower and the turbine can start producing power before the rated wind speed.



Figure 26: Sunny Sky X4108S

5.2.5 DC-DC Converter

The Final design that we have decided to select is a three-channel interleaved boost converter. We feel that the benefits of using such a design outweigh the cons of requiring a more complex control theory. A three-channel interleaved boost converter steps up the input voltage to the target output voltage. For our system we designed all three inductor channels to have the same inductance. This is done because the small benefits gained by having differing inductances is outweighed by the added complexity to the control system and the additional microcontroller required. In the Figure 27 below, is the current schematic for our three-channel interleaved boost converter. The top section of the diagram, represents the control theory for the MOSFETS used in the circuit. The three MOSFETS connected directly after the inductors all operate 120 degrees out of phase, while the constant represents the duty cycle that the MOSFETS will be operating at. Unlike in a traditional boost topology, we have replaced the diodes with MOSFETS that operate inversely to the MOSFET on the same channel as them. For example: when MOSFET11 is high, MOSFET1 will be low.

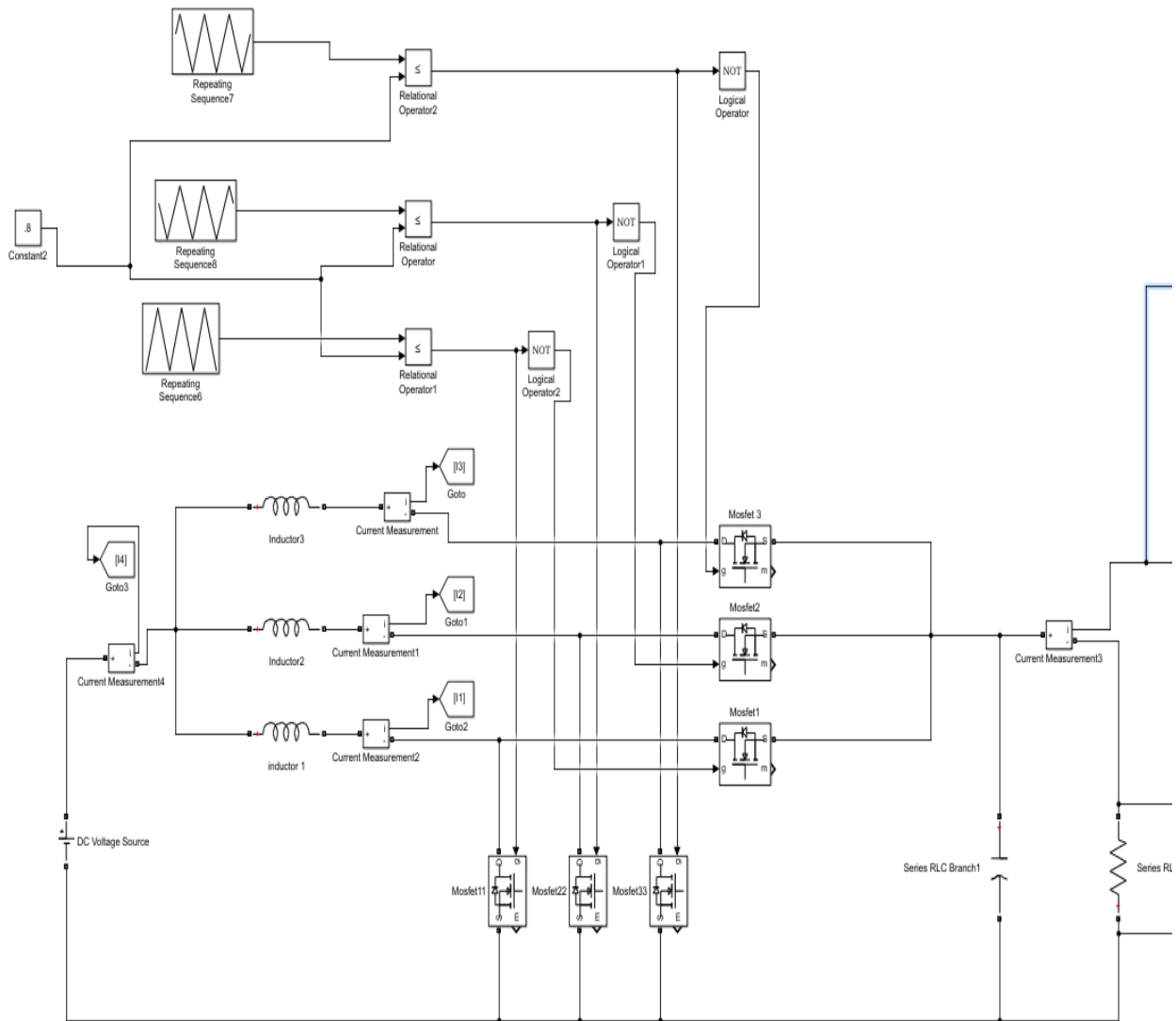

Figure 27: Three-Channel Interleaved Boost Converter

The interleaved boost Figure 27 above, required several parts to be purchased. We bought three inductors, purchased six gallium nitride MOSFETS, a filter capacitor and Arduino for pulse width modulation. We also required a breadboard to build the prototype schematic on for testing purposes.

5.2.6 PCB

Beside the board layout selection, components selection is another important part in PCB. The most significant parts are Inductor selection and MOSFET selection. There are two main types of inductor cores that can be chosen for the wind turbine boost converter: magnetic power core and magnetic ferrite core. The advantages of magnetic powder core are low temperature which means that can be worked in a low temperature. It also can apply to switching circuit, but the cost is more expensive than powder core. For magnetic powder core, it has a low loss at high frequency circuit, but the core needs to add some air gap to improve the efficiency. In order to obtain the output parameters, there is an inductor selection tool can help us to determine the specific value that can meet the requirements.

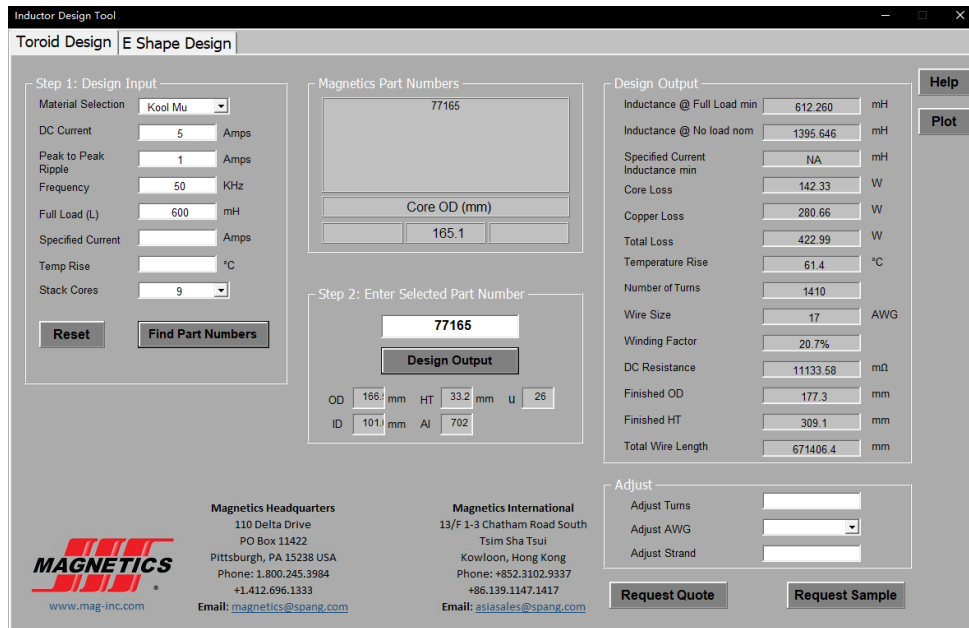

Figure 28: Inductor Selection Tool [21]

MOSFET selection, there also has a MOSFET selection tool, based on the boost converter simulation, the current and voltage can be figured out. Then the selection tool can select the correct MOSFET which can meet the requirements. The material of MOSFET is also important. For our wind turbine boost converter, there need 6 MOSFET, three of them need to use silicon-carbide, this material has a higher efficiency and frequency. Another three MOSFET can use the gallium-nitride which is cheaper than silicon-carbide.

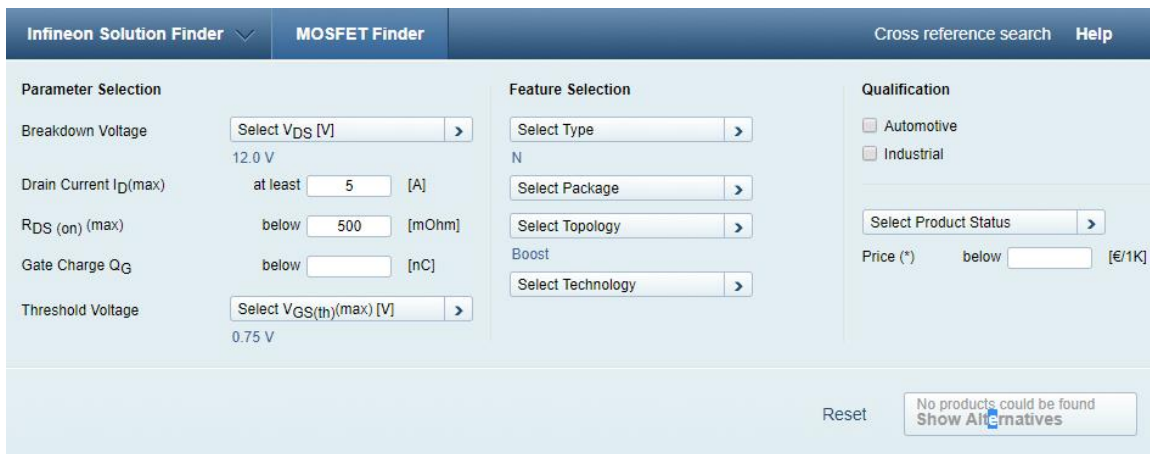

Figure 29: MOSFET Selection Tool [22]

6 PROPOSED DESIGN

Shown below in Figure 30 was the current assembly for both test teams. This assembly was just an initial collaboration from both test teams. After compiling all the part files into this assembly a few dimensional errors arose and needed to be changed in the part files and recompiled. After the CAD package was compiled and completed each of the parts were manufactured. Certain components within the assembly can be iterated on as much as possible to achieve the best solution for the project. From the CAD file it was also clear how components were being connected.

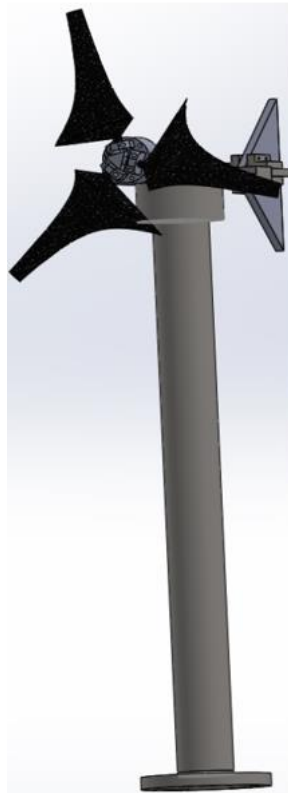

Figure 30: CAD Image of Overall Wind Turbine Design

6.1 3 ULTEM 9085 Blades

The final material of the blades has been chosen to be ULTEM 9085. This material was chosen because the ULTEM can be printed in the rapid lab at NAU, and has high modulus of elasticity in tension compared to its compressive modulus of elasticity. Shown below in Figure 31 is the current blade in solidworks. This blade has a been modified from what was done in Qblade because the root of the blade has been changed to accommodate the hub and pitching system. The cost of the ULTEM 9085 is \$80.00 for a 250 g roll by 1.75mm in diameter.

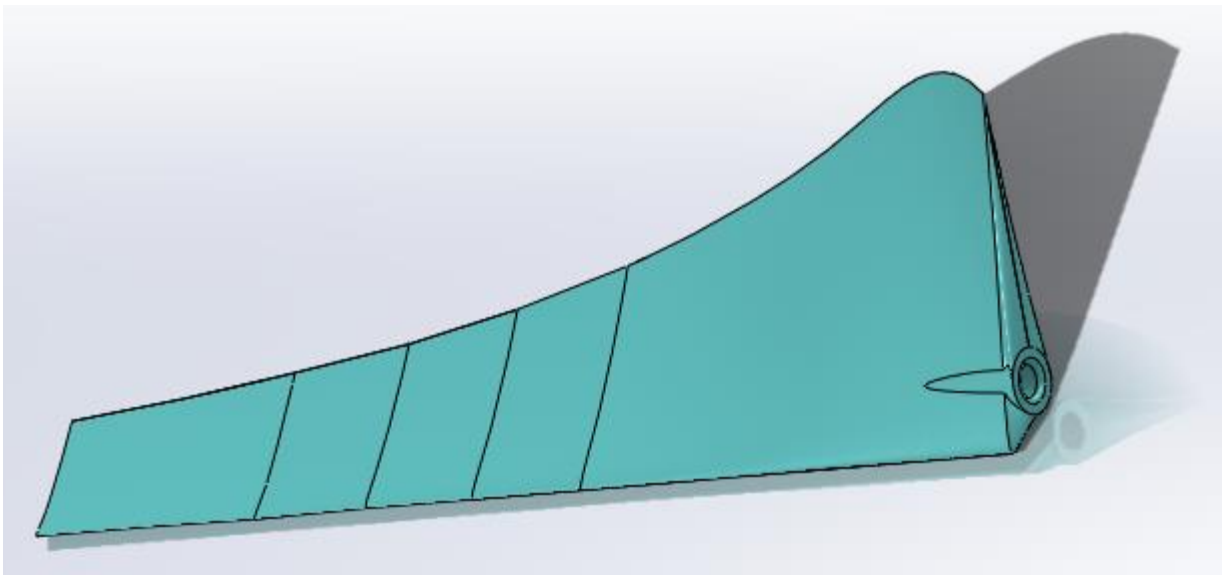

Figure 31: Blade in Solidworks

6.2 Direct Drive Aluminum 7075 Shaft

A 2 feet long and 1 inch diameter Aluminum 7075 rod from McMaster-Carr® was \$30.09. The rod of Aluminum 7075 can be machined into the design shown in Figure 23. The shaft was connected to the hub with a reverse-thread set-screw. The disk brake was connected to the shaft through an interference fit hexagonal connection shown in Figure 23. The generator was connected through its provided set-screw. Loctite® glue and primer will be used in each location to hold the components together through torques experienced during wind turbine operation.

6.3 Timken Co. 619/8-2RS Single-Row Deep-Groove Ball Bearings

The proposed bearing design for the direct drive shaft are 8 mm inner diameter single-row deep-groove ball bearings from Applied Industrial Technologies®. The chosen ball bearing type (Timken Co. 619/8-2RS Ball Bearing) can handle all relevant expected axial and radial loads while having a cost of \$21.06 per bearing, well below our overall budget. It was connected to the smaller diameter of the designed shaft in Figure 23. The housing that can hold the bearing in its location is a SKF USA SY 3/4 FM pillow block that will be connected to the nacelle through screws provided by the manufacturer. If needed upon design iterations, spacers can be used to position the bearing for vertical shaft alignment.

6.4 Permanent Magnet Synchronous AC Generator

For the final generator design, it will be a permanent magnet synchronous AC generator. The expected cost to acquire the generator is very low, only about \$30 to \$40. There are no components to actually be built for the generator, so next semester will consist mostly of testing the generator and generating power curves so that the team designing the blades will know what tip speed ratios and rotational velocities to design for. For the schedule, the majority of next semester (about 2-3 months) will be spent on generator testing. The rest of the time will be spent on acquiring the generator at the beginning of the semester and assembling it onto the turbine at the end of the semester.

6.5 3-Channel Interleaved Boost Converter

To implement the interleaved boost converter from simulation to physical hardware required a collaboration from both teams. The first step was to gather all the required components: six gallium nitride FETs, three inductors, one capacitor, and an Arduino Nano. The next step will be to size the components and order all the parts. The three inductors will all have the same value. The next step was to create the control theory

for the FETs using the Arduino Nano. From there we created a circuit on a breadboard and test it. Once the board has been tested and changes made if necessary. We designed our own PCB and will have it printed at a location in Phoenix. The goal is to have all the testing and design done by the end of the semester.

6.6 PCB Inductors and MOSFETs

For PCB design, board layout selection, inductor design, and MOSFET selection must be completed. The double-side board has a suitable size for the expected wind turbine boost converter geometrical constraints and the design can carry some surface mode components that will be needed to use in the boost circuit. For the inductor design, a magnetic powder core is the better choice than magnetic ferrite core, the two inductors in consideration. The power core can be applied to the switching circuit, and it also has a better DC bias which can improve electrical efficiency. The exact inductor can be selected using the inductor selection tools, which can figure out any output parameters that the wind turbine may need.

For the MOSFET selection, there are 6 MOSFETs that are needed for use in the boost converter circuit. For circuit functionality, 3 MOSFETs need to use silicon carbide material, because it has the highest possible efficiency from a higher frequency. The other 3 MOSFETs can implement gallium nitride material, because these 3 MOSFETs are used to dump the voltage for voltage regulation. A high efficiency for these MOSFETs is not necessary, and gallium nitride material is much cheaper; therefore, it is better for our team to reduce the expenses.

6.7 Bill of Materials

Table 11 is a small part of the Bill of Materials for Test Team A. The full Bill of Materials can be seen in Appendix D. Table 11 shows the name of the part, the quantity of each part needed, a short description of the part, the material of the part, the function of the part, and the cost of the part. The columns that are missing from Table 11 but shown in the full BOM are where the part is going to be used, the part number (if available), the dimensions of the part, and the link to where the part will be ordered. For our team the total price for materials alone was \$323.47 without any shipping or sales taxes. Assuming a high 12% sales and shipping tax brings the price up to \$362.29. The sales and shipping tax was assumed to be 12% because the average sales taxes is 8.951% in Flagstaff, AZ and assuming a roughly 3% shipping tax. Another reason to over assume the sales and shipping taxes is that when it comes time to order and purchase more parts there is extra money in the budget to account for ordering extra parts and new parts all together.

Table 11: Partial BOM

Part Name	Qty	Description	Functions	Material	Dimensions	Cost
Rod,SS,303,1/2 In Dia x 3 Ft L	1		blade root connection to hub	T303 stainless steel	0.5" X 3'	\$ 6.25
ULTEM™ 9085 3D PRINTING FILAMENT	1	Filament to use within the Rapid Lab with the Fortus 400mc	Blade material	ULTEM 9085	1.75 mm X 250 g	\$ 80.00
Hard High-Strength 7075 Aluminum rod	1		connects the rotor to generator	7075 Aluminum	1" x 2'	\$ 30.09
Loctite 26221 Threadlocker	1	Adhesive	Connects threads between shaft and hub/generator		10 mL	\$ 16.40
Loctite 19267 Primer	1	Adhesive	Primer for Threadlocker		1.75 oz	\$ 21.06
Timken Co. 619/8-2RS	1	Ball Bearing	Holds shaft in position while rotating	Steel	8mm ID, 19mm OD, 6mm Wide	\$ 28.19
SKF USA SY 3/4 FM	1	Pillow Block	Holds bearing in place while rotating	Cast-Iron	19.05 ID, 39.5mm Wide	\$ 47.10
Mosfet	6		Switching Device	Gallium Nitride		\$ 15.78
Capacitor	1	175uF	Filter	Aluminum Electrolytic		\$ 1.03
Arduino Nano	1		Microprocessor			\$ 7.32
Voltage Sensor	1		Allow microprocessor to control voltage			\$ 6.45
Magnetic wire	1		Inductor material	copper	0.043" X 50'	\$ 6.30
Magnetic powder core	6	11uH	Inductor	kool Mu Max core	4.67 x 18 mm	\$ 6.00
Turnigy XK-4082 1450KV Brushless Inrunner	1	1500 KV	Genorater	shelf	99 X 40 mm	\$ 51.50
	24					\$ 323.47

6.8 Schedule and Timeline

The entire assembly is going to be assembled when all of the components are done with their final tests. This will more than likely be late March or early April. At this point the turbine is going to be tested for functionality. If the turbine functions as expected then the turbine will be placed in a wind tunnel to see if the turbine produces the power, voltage, and current that is expected. This will also allow the Turbine to be tested for it power curve and see if the predicted power curve is close to what is being generated in the wind tunnel. The final turbine will then be disassembled and packaged into shipping containers and shipped to Chicago between 27 April - 1 May 2018, so that it will arrive before the competition starts 8 May 2018.

This can only be done once each of the individual components have go through all their tests. The following sections will discuss the timeline and schedule for each of the components.

6.8.1 Blades

The raw filament is going to be ordered in the first week of the semester. When the material is received the rapid lab is going to be contacted about printing our blades. After the first couple of blades are printed the tests on the blades are going to be conducted. From the results of the tests either the blades will be modified to meet the requirements for the blades or a new material is going to be selected that has high strength properties, but more than likely the blades will just be modified to meet the strength requirements. After the tests are conducted the blades will be assembled with the pitching system and that sub-assembly is going to be tested to make sure that the components work together as expected. The blades are more than likely needed to be redesigned a couple of time to work with the attached components.

6.8.2 Drivetrain

The Aluminum 7075 bar material was ordered from McMaster-Carr® in the beginning of January, and it took about two weeks until it was delivered. The machining will be done upon material retrieval until a geometry acceptable for the constraints that were created by the wind turbine design is found (which is expected to be in early April). Finally, the shaft will be inserted into the final wind turbine assembly once

every component is ready.

6.8.3 Bearings

The bearings were not ordered in the beginning of January, it was ordered with the brake system. Once the shaft was machined to the proper dimensions, the bearing was be fitted onto the shaft and the brake mechanism. The load testing was conducted once the active pitching rotor was attached to the shaft. No machining was needed for the bearing or pillow block; however, machining spacers for shaft vertical alignment may be necessary. The machining was be done before the final wind turbine assembly.

6.8.4 Generator

The generator will be ordered during break in early January. Once winter break is over, the dyno will have to be fitted with a new mounting system to accommodate our generator. It should take about a week to create this block. Once it is made, the generator will be extensively tested on the dynamometer for 1-2 months to ensure that the output from it matches the desired output values for the conversation. If the actual values are drastically different from the expected ones, then the generator selection may be revisited to get actual values that are closer to the expected ones. If the values are close though, then the generator will be assembled onto the turbine and tested with the other power electronics components as a full system for the rest of the semester, which will be about 1.5 months.

6.8.5 DC-DC Converter and PCB

At the beginning of the next semester, we will order the components. Then, all the electrical engineering major team members need to build the PCB prototype, which should take two-three weeks. The prototype will consist of the DC-DC converter design and the rectifier on one PCB. Afterwards, the prototype board design will be sent to a professional manufacturer. Upon retrieval of the professionally manufactured PCB, we will solder all the required components onto it. The board will then be tested with an oscilloscope before implementing it onto the wind turbine assembly. Once the test is consistently successful, we will assemble the board with wind turbine for the assembly test and then the competition in May.

7 IMPLEMENTATION

7.1 Manufacturing

The components that need (or may need) manufacturing procedures are: the blades, drivetrain, bearings, and PCB. Also, there needs to be coding for the other electrical components.

7.1.1 Blades

The blades will be printed using the Fortus 400 mc. The blades will be printed using ULTEM 9085. Since the blades are being printed there is little that needs to be done with the blades. The blades are being printed at an angle of 30° above the horizontal. This is being done to have a balance between beads that are radial and length of the blade. The balance is the strength of the bead for that the forces that are going to act on the blade. Since most of the forces on the blade are going to be in the radial direction the beads should be mostly in that direction because the material does better in tension rather than compression. The blades being manufactured are going straight from the SolidWorks part file (saved as an STL file) to the printer. The final blades are also going to be printed at 100% infill to have the highest strength from the blades.

Since the blades and blade roots are separated in our design the blade roots are going to be manufactured separately. The blade roots are made out of T304 stainless steel. The blade roots are turned down on a lathe. The stock metal that is being used is from 3/8 inch round bar stock. With a length of 3.5 cm, 1.5 cm is being untouched. The other 2 cm is being turned down to approximately 0.6 cm (0.236 in).

7.1.2 Drivetrain

The drivetrain will be one of the last components that will be machined because the shaft design can be changed due to minor changes in the generator, rotor, and braking system design. A M10x1 thread needs to be machined on the end of the 10 mm diameter section of the shaft to connect it to the rotor. A hole will be machined on the back side of the shaft to make an interference fit to connect it to the generator. For the brake system's hexagon, another hole will be perpendicularly machined on the 12 mm diameter section and it will be 6.5 mm from the section that will connect to the generator. After machining is done, assembling the shaft will begin from the generator by the interference fit and loctite glue. Then, the Hexagon part of the brake system will be fixed on the shaft. Finally, the rotor will connect to shaft by the threaded part. The resources that are going to be used to machine the drivetrain are lathe, drill, aluminum rod, and loctite glue.

7.1.3 Bearing

The bearing for the shaft is now a component of the braking system assembly, as to ease the difficulty of manufacturing for the brake system. There will be no need for machining the bearing pillow block, unless we need spacers to elevate it to the correct height, which can be machined with a mill lathe. Once machining is finished, the brake assembly will be put together, then the shaft will be fitted into the bearing of the pillow block, and the whole assembly will be placed onto the nacelle for the final assembly.

7.1.4 PCB

In the second semester, PCB schematic design and layout design are the most significant parts for the Electrical Engineers. All the components have already been finalized by Dr. Yaramasu at the beginning of this semester. The PCB layout and schematic has been designed based off the simulations from last semester. The most difficult part of designing the PCB layout is the positioning of the components. An Arduino Due has been selected as the microprocessor for our project, it will be attached to several pins coming out from the PCB. The pins have been measured to fit the dimensions of the Arduino so that it should fit in precisely. Once we receive the board in the following week, the next step is to solder the components on to the PCB. After that is complete the Electrical Engineers can begin the testing phase of project. Assuming all is correct with the PCB design, we will have ample amount of time to test and fix any problems with the design. Once the testing is successful, we will order a brand more PCB's for the competition in Chicago.

7.1.5 Coding

Another important aspect of the design is the coding behind the design. Without correct code the design will not function as intended. Currently, the team is working hard to complete the code for the boost converter, hub, pitching and braking systems. This is expected to be complete by the time the PCB is soldered.

7.2 Design Changes

7.2.1 Blades

After initial testing of bonding the blades to the blade roots the blade roots needed to increase the smaller diameter a little because one broke while testing the bond strength. While the diameter of the blade root needed to increase the hole in the bottom of the blade need increase as well. The hole was increased from 0.5 cm to ¼ inch. The reason for this increase from a metric to a standard size is because after receiving a couple of small test blades the hole needed to be drilled out to remove the support material.

7.2.2 Drivetrain

The design of the drivetrain changes to supplement the surrounding components. The brake has its hexagon part that can be attached on the shaft, and it has an inner diameter of 12 mm. The hexagon part where the disk brake will be attached is going to be pinned on the shaft with pin size of 4 mm. The generator has changed so it has new shaft diameter which changes the shaft design. The diameter of the section of the shaft that connects to the rotor has changed from 8mm to 10mm for structural integrity. The shaft design has changed to supplement the changes that were made on the overall design. The new design is shown in the figure below.

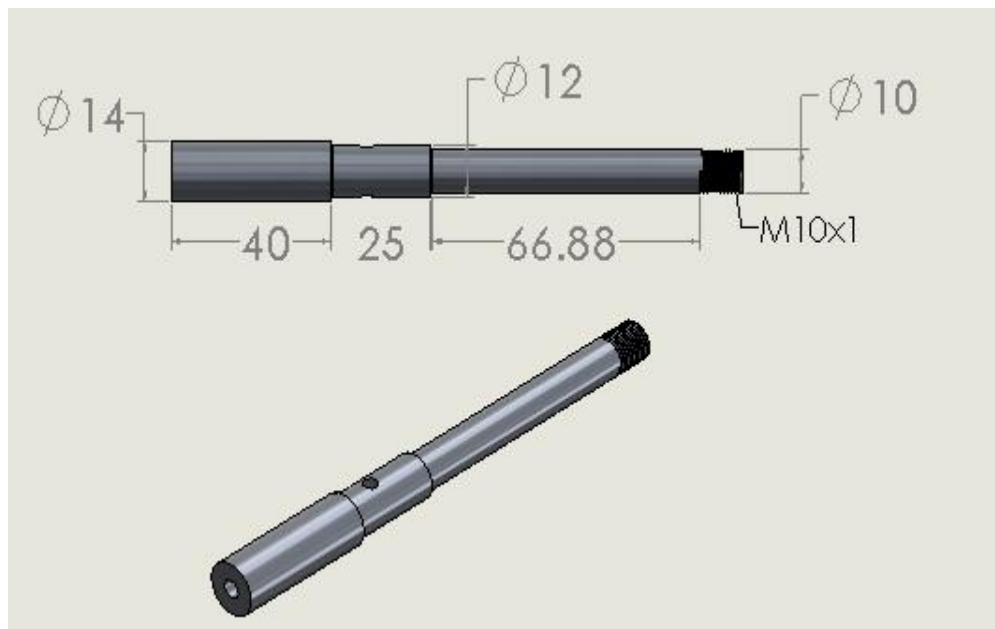

Figure 32. New Drivetrain Design

7.2.3 Bearing

The bearing that holds the drivetrain in position as it transfers rotational kinetic energy has changed to simplify the manufacturing process. Instead of using the Timken Co. 619/8-2RS Ball Bearing and the SKF USA SY 3/4 FM pillow block, the shaft pillow block supplied with the brake assembly will be used, which is shown in the figure below. This bearing pillow block is expected to handle all of the expected loads, as it is design to handle all of the expected loads within a Baja vehicles, which are more strenuous than our

wind turbine application.



Figure 33. Brake Assembly Shaft Pillow Block

7.2.4 Generator

Once it was decided that the system would be changed to a much lower voltage system, the generator selection had to change to accommodate that. The target output voltage range changed from 0-10V to 0-3V, which required a much higher KV generator to produce this lower voltage. The final generator that was selected is the Turnigy XK4082 1500KV inrunner, which is pictured below. This generator was selected because of its high KV rating and inrunner design. An inrunner motor has the magnets rotating inside the coils as opposed to outside of them, which is good for high RPM, low torque applications. The drawback of this type of motor is that it is much larger, which takes up more space on our turbine, and it also has only 4 poles, which leads to more cogging torque during startup. However, it was determined that the pros of this generator outweighed the drawbacks and it was selected as our final choice.



Figure 34. Final Generator Design Decision

7.2.5 DC-DC Converter

The original plan to step the voltage up to 16V has changed in favor of a new design for the boost converter. Because of the durability test, which requires that the system outputs a constant 5V output while a variable resistor is used to change the value of the load. The team has decided to design the boost converter to always output 5V. Having two different output voltages would have been difficult to accomplish. The implications

of these changes required the team to resize the values of the components. To achieve the constant output voltage required a change in the control theory. Before the boost converter was going to operate using a Maximum power point tracking algorithm. However, it will now be using a voltage oriented control, to achieve a constant 5V output from the boost converter.

7.2.6 PCB

At the beginning of the second semester, inductor selection has been changed due to the efficiency is much lower than the previous design. After get the approval from Dr. Yaramasu, we have been chosen the toroidal inductor through Dig-Key. Then when we testing the boost converter using breadboard, serval problems shown to us. The figure shows the result of the testing. Although the boost converter achieve the voltage step up, there is no current through the whole circuit, which means that it is open circuit in this boost converter. the possible mistakes is listing below: firstly, the soldering is bad which means there is an open circuit somewhere in the circuit. Secondly, there is no load for this circuit. The final assumption might be the voltage is so small which cannot reach to the gate voltage of the MOSFET. In order to solve the first problem, a multimeter can be used to check the connection between the two component. For the second problem, adding an adjustable resistor can be figure out. The last problem is more complicated than the previous question. In order to increase the voltage which can be reach to the gate voltage. A gate driver can be used to increase the voltage. when the components were delivered, we can test the board again to make sure there is completely successful.

8 REFERENCES

- [1] "Collegiate Wind Competition," US Department of Energy, [Online]. Available: <https://energy.gov/eere/collegiatewindcompetition/collegiate-wind-competition>. [Accessed 8 November 2017].
- [2] B. Merchant, "US Wind Power Is Expected to Double in the Next Five Years," VICE Motherboard, 12 March 2015. [Online]. Available: https://motherboard.vice.com/en_us/article/vvbq33/american-wind-power-is-expected-to-double-by-2020. [Accessed 8 November 2017].
- [3] US Department of Energy, "Collegiate Wind Competition 2018," 28 August 2017. [Online]. Available: 2017. [Accessed 8 November 2017].
- [4] M. P. A. M. M. Jureczko, "Optimisation of wind turbine blades," *Journal of Materials Processing Technology*, vol. 167, no. 2-3, pp. 463-471, 2005.
- [5] K. N. Richard Budynas, Shigley's Mechanical Engineering Design, New York: McGraw-Hill Education, 2015.
- [6] H. Trencher, "Differences Between AC & DC Generators," It Still Works, [Online]. Available: <https://itstillworks.com/differences-between-ac-dc-generators-7636332.html>. [Accessed 8 November 2017].
- [7] D. L. Jones, PCB Design Tutorial, Alternative Zone, 2009.
- [8] GE Energy, "uchicago.edu," 2009. [Online]. Available: <http://geosci.uchicago.edu/~moyer/GEOS24705/Readings/GEA14954C15-MW-Broch.pdf>. [Accessed 8 November 2017].
- [9] The Home Depot, "Nature Power 400-Watt Wind Turbine Power Generator for 12-Volt System-70500," Nature Power, 2017. [Online]. Available: <http://www.homedepot.com/p/Nature-Power-400-Watt-Wind-Turbine-Power-Generator-for-12-Volt-Systems-70500/203916953>. [Accessed 8 November 2017].
- [10] Northern Arizona Wind & Sun, "Primus Wind Power Air 40 12 Volt DC Turbine," 2017. [Online]. Available: https://www.solar-electric.com/primus-wind-power-air-40-12-volt-generator.html?gclid=EAIaIQobChMIoIm9_cnd1gIVCbbACh1jSAI5EAKYBCABEgK8n_D_BwE. [Accessed 8 November 2017].
- [11] "Single Row Deep Groove - Single Row Ball Bearings," AST Bearings, 8 November 2017. [Online]. Available: <http://www.astbearings.com/single-row-deep-groove.html>. [Accessed 8 November 2017].
- [12] "Tapered Roller Bearings," AST Bearings, [Online]. Available: www.astbearings.com/tapered-roller-bearings.html. [Accessed 8 November 2017].
- [13] W. L. At?, Artist, *gearbox*. [Art]. 2017.
- [14] C. Fitters, Artist, *Propeller Shaft*. [Art]. 2017.
- [15] Applied Industrial Technologies, "NTN Bearing Corp. | 6008ZZV23 | Single Row Deep Groove," 2017. [Online]. Available: <https://www.applied.com/c-ntn-bearing-corp--6008zzv23/p/101507147>. [Accessed 8 November 2017].
- [16] Applied Industrial Technologies, "Timken Co. | T182 904A1 | Tapered Roller Thrust Bearing," 2017. [Online]. Available: <https://www.applied.com/c-timken-co--t182-904a1/p/101193076>. [Accessed 8 November 2017].
- [17] Alternative Energy Tutorials, "DC Generator is more than a PM Generator Design," 2013. [Online]. Available: <http://www.alternative-energy-tutorials.com/energy-articles/dc-generator-design.html>. [Accessed 8 November 2017].
- [18] T. K. D. R. S. J.S. Anu Rahavi, "Design and Analysis of Interleaved Boost Converter for Renewable Energy Sources," in *International Conference on Computing, Electronics and Electrical Technologies (ICCEET)*, Tmail Nadu, India, 2012.

- [19] H. B. S. P. Carl Ho, "Practical Design and Implementation Procedure of an Interleaved Boost Converter Using SiC Diodes for PV Applications," *IEEE Transactions on Power Electronics*, vol. 27, no. 6, pp. 2835-2845, 2012.
- [20] traceparts, "3d models SKF : Deep groove ball bearings, single row, stainless steel, shields," 2017. [Online]. Available: [https://www.tracepartsonline.net/\(S\(3ohrmvypg1155hcos4gckdsb\)\)/partdetails.aspx?Class=SKF&PartID=10-28092016-118829&descr=Deep+groove+ball+bearings%2c+single+row%2c+stainless+steel%2c+shields](https://www.tracepartsonline.net/(S(3ohrmvypg1155hcos4gckdsb))/partdetails.aspx?Class=SKF&PartID=10-28092016-118829&descr=Deep+groove+ball+bearings%2c+single+row%2c+stainless+steel%2c+shields).
- [21] Magnetics, "Magnetics - Inductor Design," 2017. [Online]. Available: <https://www.mag-inc.com/Design/Design-Tools/Inductor-Design>.
- [22] Infineon, "Tools - Infineon Technologies," 2017. [Online]. Available: <https://www.infineon.com/cms/en/tools/>.

APPENDIX A: House of Quality (HoQ)

System QFD		Technical Requirements																			
Customer Needs	Weighting (Eq. 1)	1. Power Generation	2. Electrical Grounding	3. Electric Wire Distribution	4. Transportability	5. Assembly	6. User Friendly	7. Safety	8. Durability	9. Maintenance	10. Aesthetics	11. Material Resources	12. High Voltage	13. High Speed	14. High Power	15. High Temperature	16. High Reliability	17. High Accuracy	18. High Precision	19. High Stability	
Power Generation	4.5	9	9	9	3	9	9	9	1	9	1	9	9	9	9	9	9	9	9	9	
Electrical Grounding	1.0	0	0	0	9	9	9	9	3	3	0	0	3	1	1	1	1	0	3	0	9
Electric Wire Distribution	2.6	0	1	1	9	9	3	9	1	1	0	0	3	3	3	3	3	0	3	0	9
Transportability	4.0	3	9	9	3	3	1	0	0	3	3	9	3	3	3	3	3	3	9	9	3
Assembly	4.2	3	9	9	9	3	3	0	1	9	9	9	9	9	9	9	9	9	9	9	9
User Friendly	3.0	1	9	9	9	1	1	9	9	9	3	3	9	9	9	9	9	3	9	9	3
Safety	2.0	9	0	0	9	9	3	9	9	9	1	9	9	9	9	9	9	3	1	1	3
Durability	4.8	9	3	3	3	1	3	1	3	3	9	9	9	9	9	9	9	9	1	1	3
Maintenance	3.9	9	3	3	9	3	1	3	9	3	9	9	9	9	9	9	9	9	9	9	3
Aesthetics	2.7	1	1	1	3	1	1	0	1	1	3	3	3	3	3	3	3	3	1	1	3
Material Resources	9.0	9	9	9	9	1	3	3	3	3	9	9	9	9	9	9	9	3	9	9	9
Technical Requirement Targets Tolerance		0.5	-0.5cm	-0.5cm	0	+0.2m	-5V	C	-3V	Y	#	-0.5cm	+2W	2m/s	0m/s	1kW	4m/s	-2,+1	4%	-19%	5%
Technical Requirement Targets		22	Fit	Fit	≥NEMA 1	1m (2x), 2m	48V	0	16V	Y/N	2 to 4	45cm	10W	5m/s	11m/s	2kW	25m/s	7	20%	59%	90%
Absolute Technical Importance		248	254	254	279	147	131	125	175	161	269	309	314	312	312	312	312	219	278	267	253
Testing Procedure (TP#)		N/A	N/A	N/A	N/A	N/A	N/A	N/A	N/A	N/A	N/A	N/A	N/A	N/A	N/A	N/A	N/A	N/A	N/A	N/A	N/A

APPENDIX B: Functional Decomposition

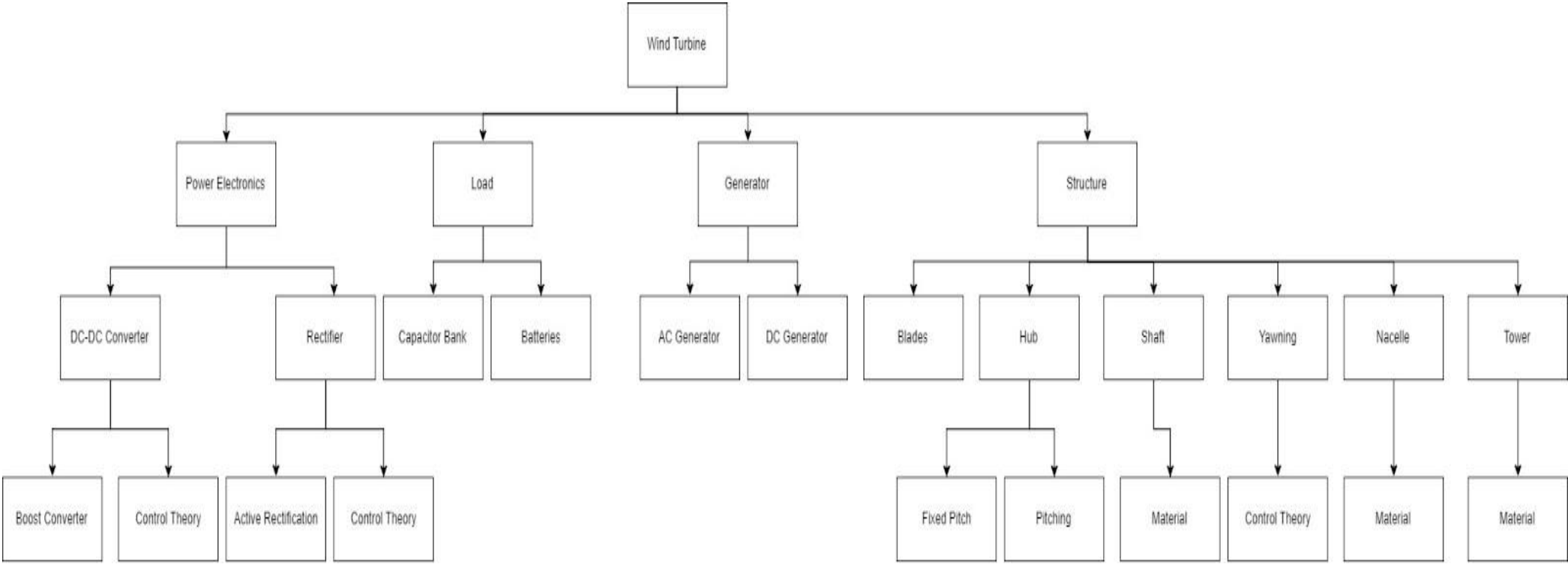

APPENDIX C: Gantt Chart

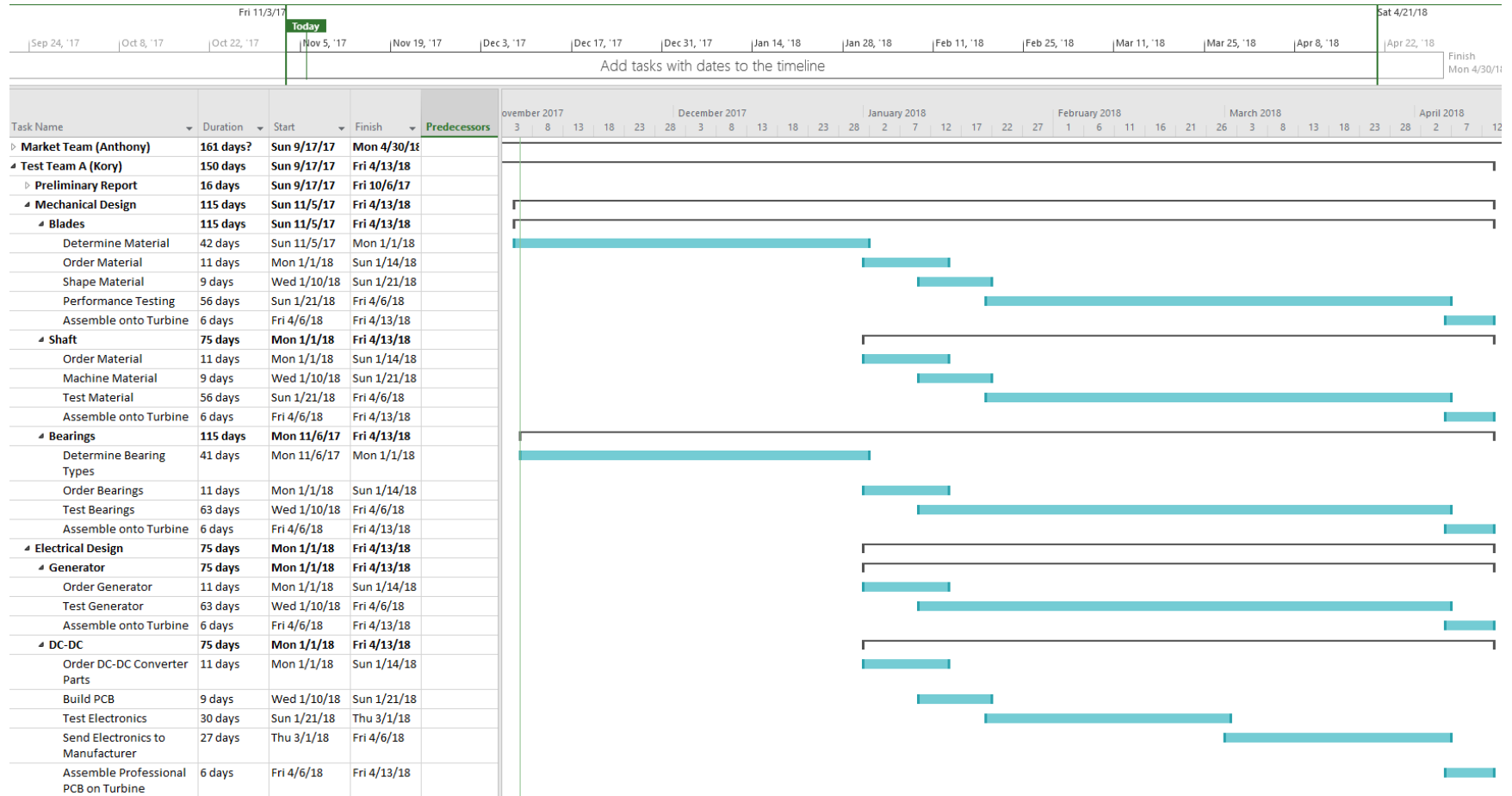

APPENDIX E: Shaft Fatigue Analysis MatLab Code

```
%Shaft Fatigue Analysis MatLab Code
d = input('Enter the diameter: ');
Sut = input('Enter Ultimate Tensile Strength: ');
Sy = input('Enter Yield Strength: ');
Sep = (1/2)*Sut; %S'e<1400MPa
a = 4.51;
b = -0.265;
ka = a*((Sut)^b);
kb = 1.24*(d^(-0.107));
kc = 0.59;
Se = ka*kb*Sep;
Ma = input('Ma: ');
Tm = input('Tm: ');
kt = input('kt value: ');
kts = input('kts value: ');
q = input('q value: ');
qs = input('qs value: ');
kf = 1+(q*(kt-1));
kfs = 1+(qs*(kts-1));
A = sqrt(4*(kt*Ma)^2);
B = sqrt(2*(kfs*Tm)^2);
ns = 1/(((8*A)/(pi()*Se*d^3))* (1+(1+((2*B*Se)/(A*Sut))^2)^(1/2)))
```

APPENDIX F: Bearing Catalog Load Rating MatLab Code

```

%Bearing Catalog Load Rating code for bearing selection
%Assumptions on Report Paper apply to this code%Assumed Values
a = input('a Value for bearing: '); %Cylindrical and Tapered Roller
R = 0.99; %Reliability
V = 1; %Rotation factor
x_0 = 0; theta = 4.48; b = 3/2; %Weibell model used
a_f = input('Application Factor: ');
L_D = input('Desired Life (hrs): ');
L_R = input('Rated Life (hrs): ');
L = input('Length of Shaft (m): ');
n_D = input('Shaft Angular Speed (rev/min): ');
R_D = sqrt(R)
x_D = L_D*n_D*60/(L_R)
%Rotor parameters analysis
%Load relevant values from Rotor
Ta_R = input('Tangential Force from Rotor (N): ');
Ra_R = input('Radial Force from Rotor (N): ');
Th_R = input('Thrust Force from Rotor (N): ');
%Bearing A Load Analysis with respect to the Rotor
x1 = input('Distance from Rotor to Bearing A (m): ');
Fr_AR = input('Reactive Load for Bearing A (N): ');
%Bearing B Load Analysis with respect to the Rotor
x3 = input('Distance from Rotor to Bearing B (m): ');
Fr_BR = input('Reactive Load for Bearing B (N): ');
%Catalog Entry Analysis with respect to the Rotor
K = input('K Factor initial guess: ');
FaeR = input('External Thrust (N) from Rotor: ');
Fi_AR = 0.47*Fr_AR/K
Fi_BR = 0.47*Fr_BR/K
if le(Fi_AR,Fi_BR+FaeR)
    Fe_AR = 0.4*Fr_AR+K*(Fi_BR+FaeR)
    Fe_BR = Fr_BR
end
if gt(Fi_AR,Fi_BR+FaeR)
    Fe_AR = Fr_AR
    Fe_BR = 0.4*Fr_BR+K*(Fi_AR-FaeR)
end
C10_AR = a_f*Fe_AR*(x_D/((x_0+(theta-x_0)*(1-R_D)^(1/b))))^(1/a)
C10_BR = a_f*Fe_BR*(x_D/((x_0+(theta-x_0)*(1-R_D)^(1/b))))^(1/a)
%Brake parameters analysis
%Load relevant values from Brake
Ta_B = input('Tangential Force from Brake (N): ');
Ra_B = input('Radial Force from Brake (N): ');
%Bearing A Load Analysis with respect to the Brake
x2 = input('Distance from Brake to Bearing A: ');
Fr_AB = input('Reactive Load for Bearing A (N): ');
%Bearing B Load Analysis with respect to the Brake
x4 = input('Distance from Brake to Bearing B: ');
Fr_BB = input('Reactive Load for Bearing B (N): ');
%Catalog Entry Analysis with respect to the Brake
FaeB = input('External Thrust (N) from Brake: ');
Fi_AB = 0.47*Fr_AB/K;
Fi_BB = 0.47*Fr_BB/K;
if le(Fi_AB,Fi_BB+FaeB)
    Fe_AB = 0.4*Fr_AB+K*(Fi_BB+FaeB);
    Fe_BB = Fr_BB;
end
if gt(Fi_AB,Fi_BB+FaeB)
    Fe_AB = Fr_AB;
    Fe_BB = 0.4*Fr_BB+K*(Fi_AB-FaeB);
end
C10_AB = a_f*Fe_AB*(x_D/((x_0+(theta-x_0)*(1-R_D)^(1/b))))^(1/a)
C10_BB = a_f*Fe_BB*(x_D/((x_0+(theta-x_0)*(1-R_D)^(1/b))))^(1/a)

```

APPENDIX D: Bill of Materials

	Part #	Part Name	Qty	Description	Functions	Material	Dimensions	Cost	Link to Cost estimate
Blades	2EXB1	Rod,SS,303,1/2 In Dia x 3 Ft L	1		blade root connection to hub	T303 stainless steel	0.5" X 3'	\$6.25	https://www.grainger.com/product/GRAINGER-APPROVED-Rod-2EXB1
		ULTEM™ 9085 3D PRINTING FILAMENT	1	Filament to use within the Rapid Lab with the Fortus 400mc	Blade material	ULTEM 9085	1.75 mm X 250 g	\$80.00	https://www.3dxtech.com/ultem-9085-3d-printing-filament/
Shaft	90465K11	Hard High-Strength 7075 Aluminum rod	1		connects the rotor to generator	7075 Aluminum	1" x 2'	\$30.09	https://www.mcmaster.com/#90465k11/=1a15qux
Loctite	100867338	Loctite 26221 Threadlocker	1	Adhesive	Connects threads between shaft and hub/generator		10 mL	\$16.40	https://www.applied.com/c-loctite-26221/p/100867338
Primer	100867308	Loctite 19267 Primer	1	Adhesive	Primer for Threadlocker		1.75 oz	\$21.06	https://www.applied.com/c-loctite-19267/p/100867308
Shaft Bearing	112307989	Timken Co. 619/8-2RS	1	Ball Bearing	Holds shaft in position while rotating	Steel	8mm ID, 19mm OD, 6mm Wide	\$28.19	https://www.applied.com/c-timken-co--619-8-2rs/p/112307989
Bearing Housing	100737442	SKF USA SY 3/4 FM	1	Pillow Block	Holds bearing in place while rotating	Cast-Iron	19.05 ID, 39.5mm Wide	\$47.10	https://www.applied.com/c-skf-usa-sy-3-4-fm/p/100737442
Electronics	917-1080-1-ND	Mosfet	6		Switching Device	Gallium Nitride		\$15.78	https://www.digikey.com/product-detail/en/epc/EPC2016C/917-1080-1-ND/5031696
	493-1673-ND	Capacitor	1	175uF	Filter	Aluminum Electrolytic		\$1.03	https://www.digikey.com/product-detail/en/nichicon/UHE2A181MHD6/493-1673-ND/589414
		Arduino Nano	1		Microprocessor			\$7.32	https://www.amazon.com/Arduino-Elegoo-board-ATmega328P-compatible/dp/B071NMBP4S/ref=sr_1_1_sspa?s=electronics&ie=UTF8&qid=1512693258&sr=1-1-spons&keywords=arduino+nano&psc=1

		Voltage Sensor	1		Allow microprocessor to control voltage			\$6.45	https://www.amazon.com/uxcell-Voltage-Detector-Terminal-Arduino/dp/B01AV0WECK/ref=sr_1_sc_2?s=electronics&ie=UTF8&qid=1512693350&sr=1-2-spell&keywords=voltage+sensor+arduiono
	18 AWG	Magnetic wire	1		Inductor material	copper	0.043" X 50'	\$6.30	https://www.amazon.com/gp/product/B00EFCX90S/ref=ox_sc_act_title_1?smid=A2TLTYG8U2QKGY&psc=1
	0077439a7	Magnetic powder core	6	11uH	Inductor	kool Mu Max core	4.67 x 18 mm	\$6.00	https://www.mag-inc.com/Media/Magnetics/Datasheets/0077439A7.pdf
Generator	XK-4082	Turnigy XK-4082 1450KV Brushless Inrunner	1	1500 KV	Generator	shelf	99 X 40 mm	\$51.50	https://hobbyking.com/en_us/turnigy-xk-4082-1450kv-brushless-inrunner.html
Total			24					\$323.47	